

HV™ SERIES TRUCK

PRODUCT BROCHURE



A TRUCK THAT WORKS AS HARD AS YOU DO.

THE INTERNATIONAL® HV™ SERIES TRUCK

The new International® HV™ Series brings intelligent solutions and powerful capabilities designed to boost your productivity. Now available with the International S13® Integrated Powertrain, the HV Series is ready to take on the toughest jobs with a new level of efficiency. With four models to choose from and a platform built for easy body integration, you're sure to find an HV Series for your specific application.



ENGINEERED FOR ANY JOB. EQUIPPED FOR ANY CHALLENGE.



Productivity often comes down to versatility and there's no more versatile foundation than the HV Series. With configurations ranging from 4x2 to 8x6, all wheel drive models (4x4 and 6x6), set forward or set-back front axles, plus clean Cab-to-Axle (CA) configurations – the HV Series has what you want for virtually every possible need.

ADVANCED. INTEGRATED. UNDISPUTED.

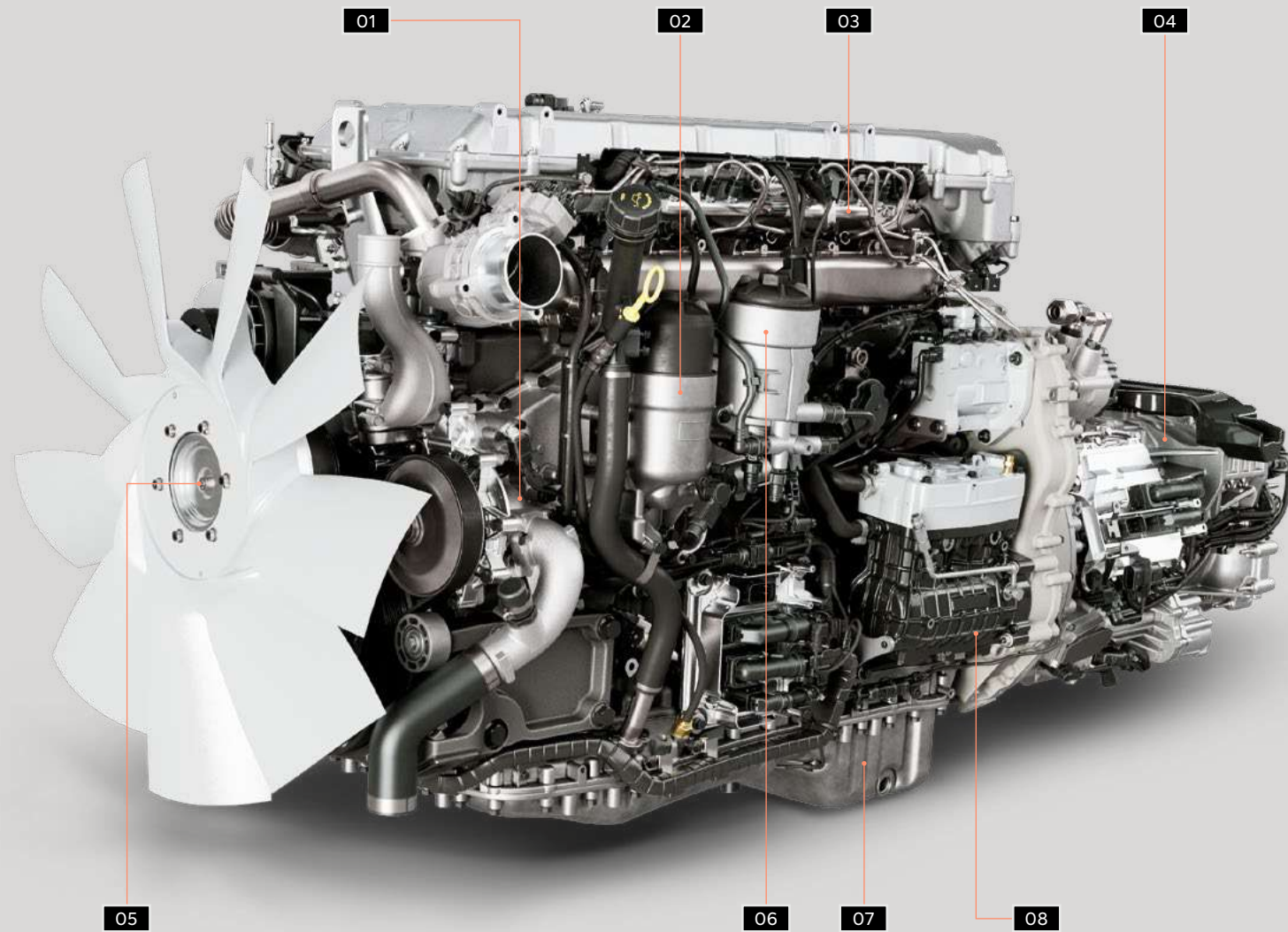

For those who face the most demanding jobs, the HV Series 515 and 615 now feature the International S13 Integrated Powertrain. This revolutionary powertrain has more of what you want and a lot less of what you don't. In fact, the S13

Integrated can meet today's emission regulations without an EGR cooler or a diesel oxidation catalyst. The S13 Integrated can also help boost productivity since you no longer need to stop work and perform active regens.

Plus, the two crawler gears of the T14® transmission help drivers navigate tight jobsites – even when hauling heavy loads.

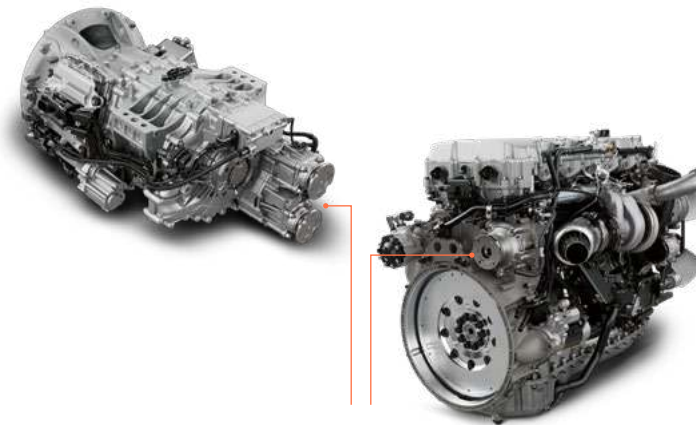
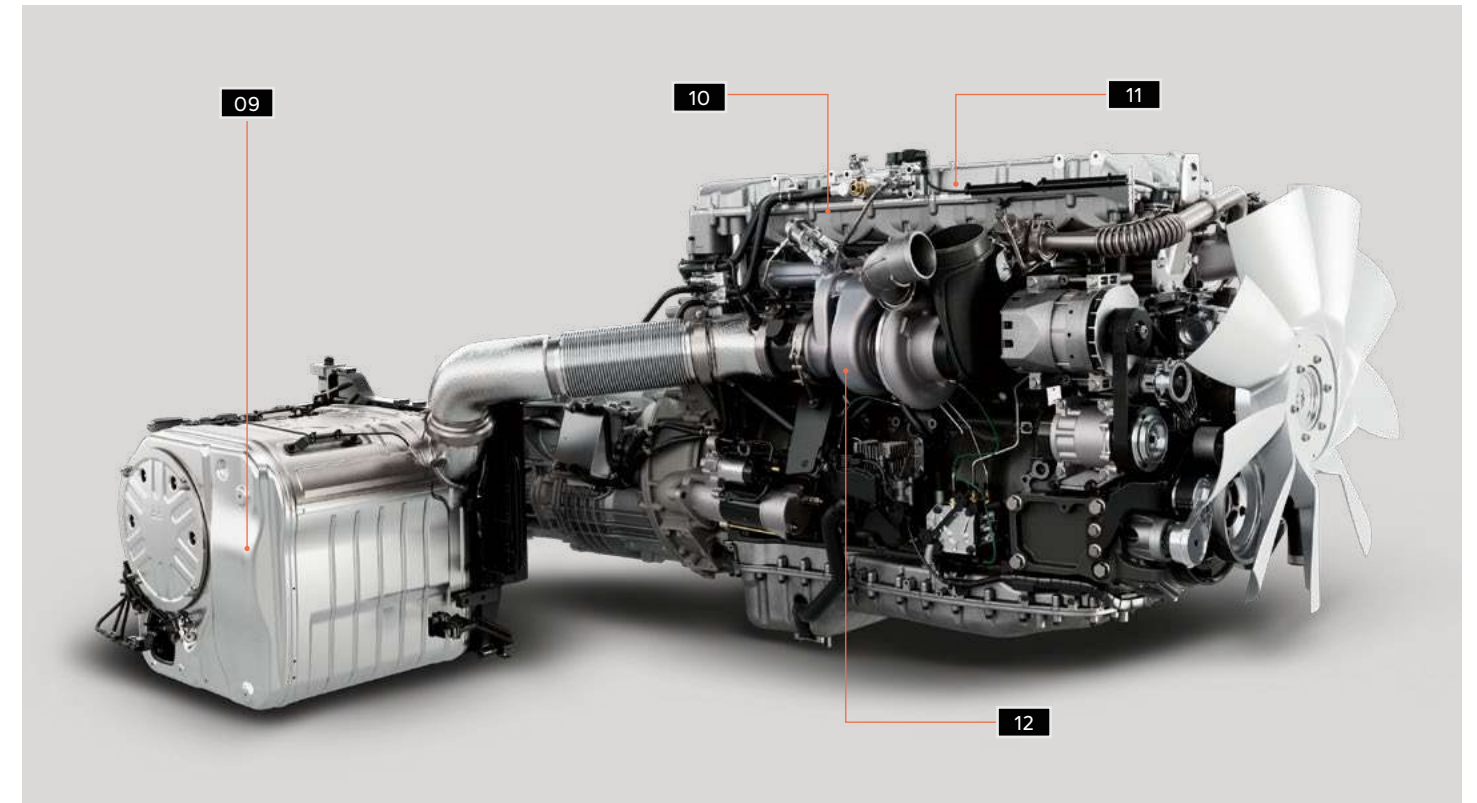

Factory-Installed PTOs available

- Single- and dual-transmission PTOs available with a variety of common SAE interfaces, installed directly at the factory
- REPTO and FEPTO options available without horsepower restrictions

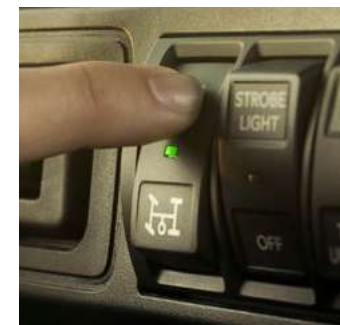

PARTS AND SPECIFICATIONS

| | | |
|----|----------------------------|---|
| 01 | Water Pump | Low displacement, Low parasitic losses |
| 02 | Oil Filter | Cartridge style |
| 03 | High-Pressure Fuel System | 1800 Bar |
| 04 | T14® Transmission | 14-speed single countershaft geartrain transmission with wide ratio spread for efficiencies on flatlands and performance on hilly terrains |
| 05 | 9-Blade Fan | For additional efficiency |
| 06 | Fuel Filter | Top access, cartridge style |
| 07 | Oil Pan | Aluminum pan provides corrosion protection (stainless steel available) |
| 08 | Air Compressors | <ul style="list-style-type: none"> • Single cylinder (iron) • Two cylinder (aluminum) • Two cylinder clutched (aluminum) |
| 09 | Dual Stage After-Treatment | <ul style="list-style-type: none"> • Compact design for more frame rail mounting space • No active DPF regen needed |
| 10 | No Cooled EGR | No Diesel Oxidation Catalyst or EGR cooler required with this advanced engine design |
| 11 | Aluminum Valve Cover | Rugged and lightweight |
| 12 | Fixed Geometry Turbo | More reliable and efficient design |

T14[®] TRANSMISSION

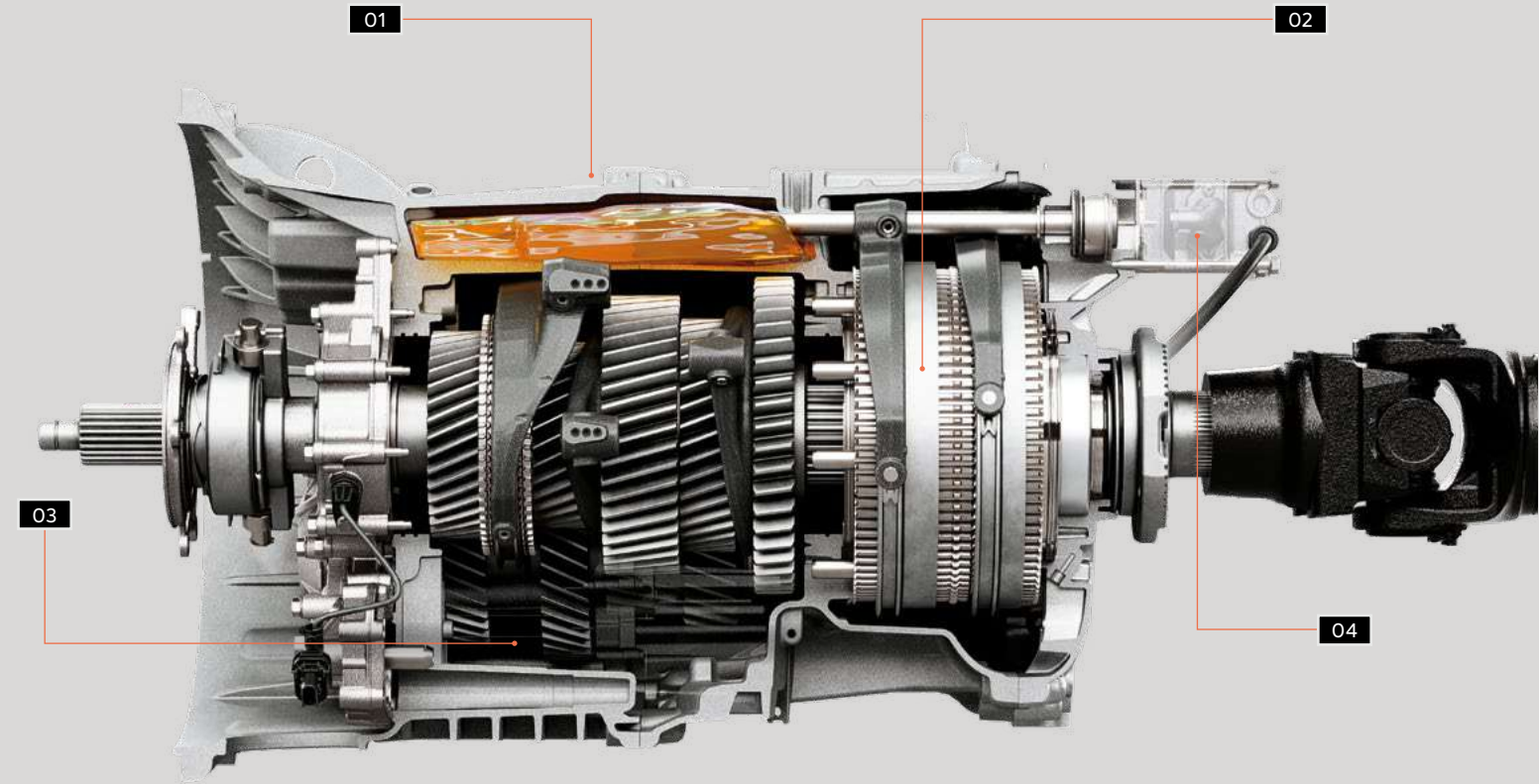

T14 AUTOMATED MANUAL TRANSMISSION PARTS AND FEATURES



| | | |
|----|---------------------------------------|---|
| 01 | Variable oil level Upper reservoir | Oil is pumped to the reservoir under lower loads to reduce parasitic losses, allowing for the continuous lubrication of gears by the oil sprayers |
| 02 | Planetary gears | The planetary gear set eliminates the need for a dedicated reverse gear, shortening the gearbox and allowing for better packaging within the chassis |
| 03 | Single countershaft | A single countershaft with helical gears lowers the overall weight of the unit without compromising the durability or performance of the transmission |
| 04 | Shift actuators | Shift actuator packaging was designed specifically for automated functionality (rather than adapted from a manual), allowing for more compact gearbox housing |



DUAL STAGE AFTERTREATMENT

Every part of the International S13 Integrated Powertrain is engineered for simplicity and durability, and its aftertreatment is no exception. It's built with a dual-stage SCR system – an advanced technology that removes the EGR cooler, diesel oxidation catalyst (DOC), and exhaust system fuel dosing – creating a system that doesn't require active regens.

KEY FEATURES

- Reduced engine soot for extended DPF service intervals
- Easy access to DPF for easy serviceability
- No diesel oxidation catalyst
- No fuel dosing
- 2 years unlimited miles, unlimited hours

Transmission Control Module (TCM)

Eco-coast and downhill speed control can be found in one module – the TCM. Combining these features into one module means the vehicle feels more natural and intuitive and, ultimately, more efficient. The transmission has an electronically controlled clutch actuator that works in sync with the engine to deliver fast and smooth shifts. Since it does not consume air during complicated maneuvers, like when you're backing a trailer into a tight loading dock, the driver never needs to stop and let the air recharge.

Driver Shift Modes

Three different shift modes (optional) for ultimate control for the driver

- **Economy** – Predictive shifting with fuel efficiency focus
- **Performance** – Perfect balance
- **Performance+** – Shifting at peak power with focus on performance
- **Off-road** – Enhanced traction

Precision Maneuvering Mode

Gives the driver more control of the vehicle at low speeds for specific movements, such as reversing into a loading dock, connecting to a trailer or navigating a crowded construction site. Torque value for pedal input is reduced. This mode allows the clutch to slip more easily for slow and smooth performance.

Paver Assist

Enables the truck to be shifted from neutral into a forward gear without the driver needing to depress the brake. This helps ensure the smooth/uninterrupted delivery of material into the following asphalt paver.

Rock Free

Extracts a truck that has sunk into the ground by rocking it back and forth (without spinning the wheels) until it's free.

Eco-Coast

Disengages the driveline when traveling downhill, using the momentum of the vehicle to save fuel.

Creep Mode

This mode allows the vehicle to automatically start moving when the brake pedal is released while the transmission is in gear. This mode is useful in high traffic and other events where constant vehicle movement is necessary without the use of the accelerator pedal.

Downhill Speed Control

This mode utilizes cruise control and the engine brake to descend at a set speed.

Hill Start Aid

The feature allows the driver to lift their foot off the brake and engage the accelerator without worry about the truck moving backwards on a hill.

THE RIGHT TOOL FOR THE TASK.

CHICAGO IL
USA
International
FROM THE FIELD
TO THE FAST LANE
EST. 1902

Every job is different. That's why the HV Series is also available with a choice of two tried-and-true Cummins® diesel engines.



CUMMINS B6.7 200-360* HP

Every aspect of the B6.7 has been engineered for reliability, durability and fuel efficiency to deliver the lowest cost of ownership with maximum uptime. Add industry-leading service from International® and Cummins, plus a two-year, unlimited mileage engine warranty, and it's easy to see why the B6.7 is the best-selling engine in the medium-duty truck market.



CUMMINS L9 260-450* HP

The Cummins L9 has established a solid reputation as a dependable engine for medium duty applications. Its XPI Fuel System features multiple injection events per cycle for smoother, quieter operation. This, combined with its proprietary Variable Geometry Turbocharger (VGT), means the L9 has the highest power density of any engine in its class. In addition, replaceable wet liners help make the L9 easier and less expensive to rebuild, plus heavy-duty roller followers, bypass oil filtration and targeted piston cooling all contribute to longer service life.

*Higher ratings limited to fire and rescue applications

DIAMOND LOGIC® ELECTRICAL SYSTEM.



HV™ Series features a programmable key fob that allows two Diamond Logic tasks to be activated with the push of a button

ENHANCE THE PRODUCTIVITY AND SAFETY OF YOUR EQUIPMENT AND CREW.

NEXT-GENERATION DIAMOND LOGIC

The International® Diamond Logic® electrical system streamlines chassis and body equipment integration for more consistent performance, increased equipment protection and enhanced crew safety. It's been considered the most advanced electrical system in the industry – and now it's even more capable.

Enhanced Remote Power Module

- 6 new analog inputs
- Pulse width modulated controls on ten outputs
- Solid state outputs
- All functions programmable with Diamond Logic Builder software
- Plastic housing for enhanced corrosion-resistance



Crane

- Require outriggers be deployed and the park brake set before allowing boom to rise
- Park brake alarm alerts driver of park brake not set using city horn
- Engine speed control with remote pedal



Utility

- Factory-installed indicator lights and audible alarms for boom out of stow and outriggers down warning.
- Protect equipment through interlocks
- Remote start/stop with emergency pump functionality



Dump

- When dump body is raised the road speed can be limited
- Dump bed and gate open indicators
- Hydraulic system monitoring performed through custom programming
- Lights automatically turn on when wipers are activated to meet the legal requirement of many states



Mixer

- Remote body switches can be custom-programmed to control concrete chutes and water valves
- Pre-trip light inspection and fluid checks
- RP1226 connectors available to allow for further third party integration

The International HV Series provides the ideal foundation for an almost unlimited number of applications. This is the result of our extensive experience working directly with customers as well as our strong engineering capabilities. Ordering the specific foundation needed for your application upfront substantially reduces time and expense upfitting the vehicle post-production.

FACTORY-INSTALLED AUXILIARY-AXLES:

Installing and certifying lift axles after delivery can be a complicated and time-consuming task. To help alleviate some of that burden, the HV Series can be ordered with a factory-rated lift axle installed directly at the factory including uprated wheels and tires. Controls for the lift axle are integrated into the wing panel through Diamond Logic – freeing up the space between the front seats for other items.

- Up to three available pusher and tag locations are available
- Can be spec'd for specific state requirements
- Factory-rated, requiring no further certification
- Can be monitored and controlled by Diamond Logic
- Controls and gauges located either inside or outside the cab per state regulations

A SOLID FOUNDATION ON WHICH TO BUILD.

BODY COMPANY BENEFITS

| | | |
|----|-------|--|
| 01 | Dump | Single 1/2", 3.35 million RBM straight frame rail provides high strength at a lighter weight and less prone to corrosion than double rail configurations There are three optional locations for supplying accessory power to the body allowing the upfitter to quickly integrate the body's lights with the chassis's Available in-cab battery box provides increased chassis packaging flexibility. |
| 02 | Crane | Customized frame ladder and component locations to meet body packaging requirements Available integral front frame extensions Three optional locations for supplying accessory power to the body for easy integration of the lights with the chassis. |
| 03 | Mixer | Light weight 9L or fuel efficient S13 engine configurations Specific cross-member location to accommodate mixer pump Factory-installed transition brackets for body mounting Inverted after-frame cross members for booster axle ram clearance. |

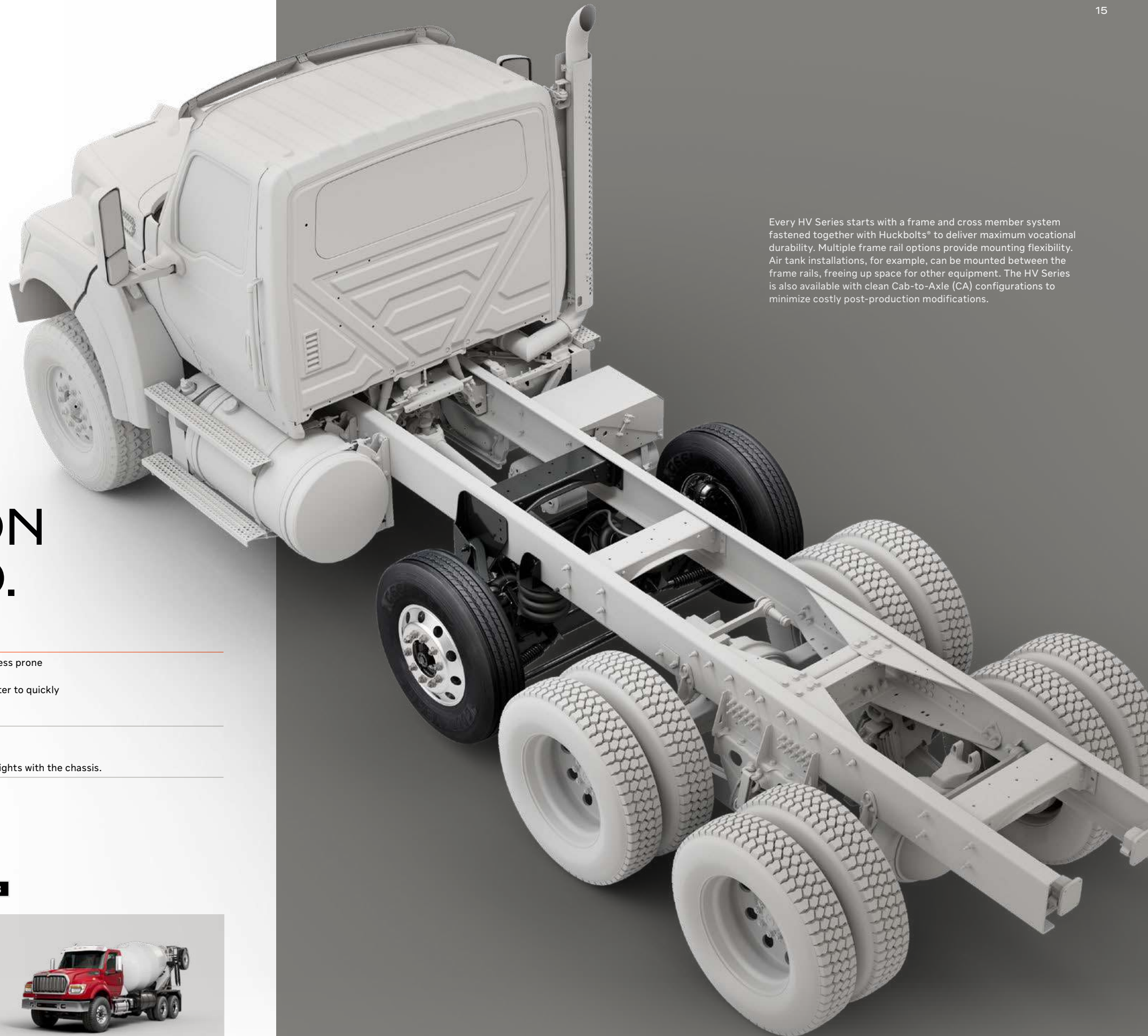

Every HV Series starts with a frame and cross member system fastened together with Huckbolts® to deliver maximum vocational durability. Multiple frame rail options provide mounting flexibility. Air tank installations, for example, can be mounted between the frame rails, freeing up space for other equipment. The HV Series is also available with clean Cab-to-Axle (CA) configurations to minimize costly post-production modifications.

01



02



03



LAYERS OF PROTECTION.

EXTREME-DUTY CAB

The cab of the HV Series is made of tough, durable, high-strength steel. The cab delivers enhanced corrosion resistance and durability for exceptional endurance for rugged applications.

Corrosion Protection

- | | | |
|----|------------------------------|--|
| 01 | InterCoat® ChemGuard Coating | Coated steel used in toe boards and floor panel for enhanced corrosion protection. |
| 02 | Spray-On Liner Coating | This available polyurethane and polyurea formulation creates a protective tray on the cab floor that contains spills as well as any of nature's elements that make their way inside. |
| 03 | Reinforced B-Pillars | Reinforced B-pillars help support optional cab-mounted exhaust. |



CORROSION RESISTANCE

To ensure long cab life and greater reliability, the cab is protected against corrosion using E-Coat and all outside panels utilize galvanized steel.

E-Coat Paint Process

- | | |
|----|------------------|
| 04 | Clearcoat |
| 05 | Base Coat |
| 06 | E-Coat |
| 07 | Galvanized Steel |

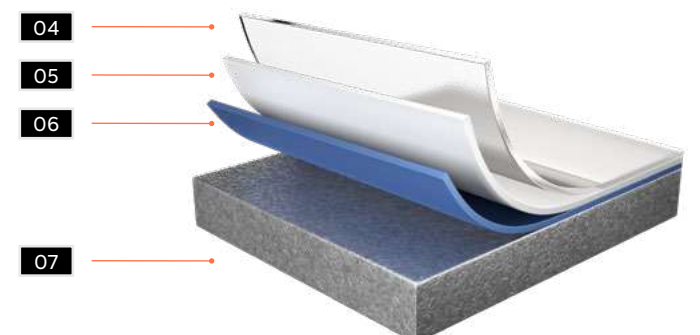

SEE MORE. DO MORE.

The International HV Series interior was designed based on a meticulous study of driver movements. Even the placement mirrors was optimized so drivers turn their heads less, making it easier to keep their eyes on the road while reducing neck strain and increasing comfort.



Drivers can now see up to 53 inches closer to the vehicle than the previous generation HV Series.

Visibility on the job site is crucial when it comes to safely and effectively completing the task. The new sloped hood of the HV Series means increases the forward visibility for drivers and can help reduce work-site mishaps.

The HV Series is engineered to provide an inside wheel cut of up to 50°, which delivers a curb-to-curb turning radius of only 27 feet and 10 inches, saving drivers time and boosting productivity.

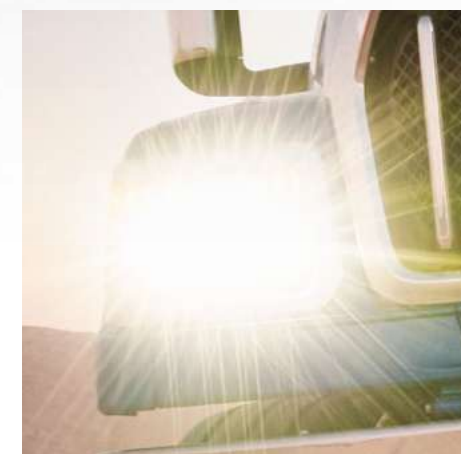
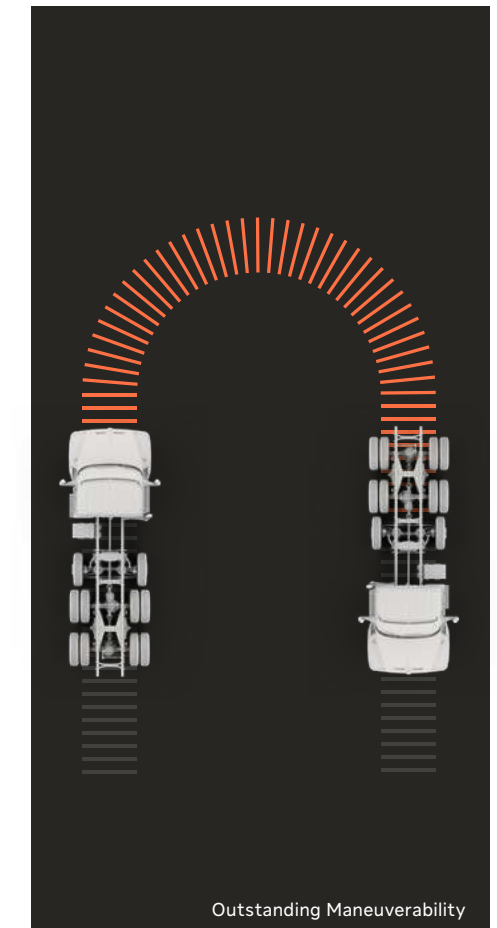

LED Headlamps

- Winter visibility can often be challenging – especially at night. That's why the HV Series is available with heated LED headlamps. Approximately 30% brighter than halogen, these LED headlamps can illuminate the road ahead year after year.

- 10 year/350k mile estimated lifespan
- Durable, Lexan LS-2 lens
- Available heated function features internal thermostat for automatic activation
- Front bumper halogen lamps are standard (LED optional)

A COMFORTABLE WORKING ENVIRONMENT.

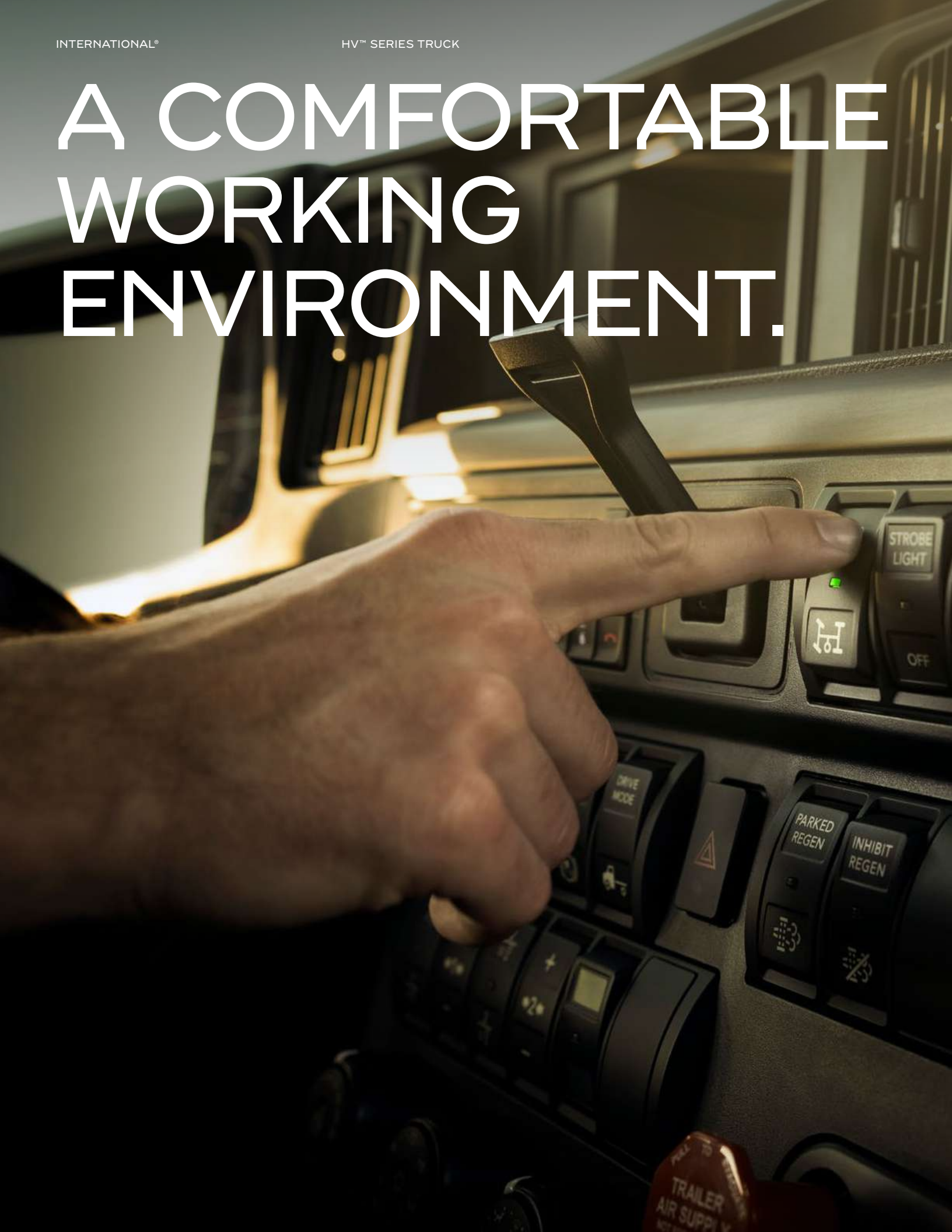

The premium gauge cluster includes a customizable digital display that provides a wealth of information for the driver, including:

Real-time fuel economy

Axle load*

Custom gauge settings*

Safety indicators*

Digital speedometer

Tire pressure*



*When added with optional feature code for required sensors

A well-designed seat should help the driver stay fresh and alert. That's why the seat in the HV Series has so many adjustments. It can now be tailored to suit drivers of all shapes and sizes, incorporating features normally only found in luxury automobiles.

Seat Cushion Adjustment

- Controls the bottom seat cushion length and tilt
- Helps accommodate drivers of all heights by distributing leg support

Fore/Aft Isolator & Adjustable Shock Absorber

- Sometimes known as a "chugger," the fore/aft isolator dampens the movement/jostling caused by various loads
- The adjustable shock absorber can vary the stiffness of the ride to match the road profile

Seat Length and Height Adjustment

- The height and length adjustment allows drivers to find the perfect driving position
- Pneumatic lumbar and side bolster supports
- The two-chamber lumbar adjustment is especially appreciated by drivers who spend long hours behind the wheel
- Pneumatic side bolsters provide additional upper body support and help the driver sit more upright

Seat Backrest and Armrest

- The adjustable backrest has a reclining range between 6 – 23 degrees
- The armrest is designed to provide support for drivers of various sizes

Seat Climate Control

- Active seat ventilation helps keep drivers and passengers comfortable on a long drive in any weather
- Two fans draw fresh cabin air into the seats, allowing the air to circulate and keeping perspiration to a minimum
- A sensor is located in both the seat and backrest to ensure uniform temperature distribution

International is the first and only OEM to create connected solutions built for how you do business - designed on an open architecture, integrated with over 30 third party telematics providers, and compatible with all makes and models.*

INDUSTRY-LEADING CONNECTIVITY.

Take your performance to the next level. Our connected vehicle technology includes tools designed to give your business and operations that extra edge.

5 Years On Us

Advanced Remote Diagnostics is included for five years standard on new HV Series.

OTA Programming

Ensure peak performance with remote software calibration and programmable parameter updates to the International S13 Integrated Powertrain — anytime, anywhere.

Fleet Health Monitoring

Weekly reports on vehicles showing fault codes that are most likely to suggest a risk of roadside failure.

Gateway Integrations

Our factory installed telematics system can connect you to select fleet management and compliance software providers seamlessly, without the cost and complexity of additional hardware installation on your vehicle.

* For most commercial vehicles powered by diesel engines, 2007 MY and later.

Our Advanced Remote Diagnostics platform features:

- Reports on vehicle health issues that include severity ratings, likely needed parts and service, and recommended actions.
- Comprehensive vehicle health reports that include performance data, fault history and more.
- Up-to-date GPS location with customizable geofencing reports that can help ensure vehicles are where they need to be.
- Insights delivered how you need it — via our online portal, your email inbox, a mobile app and more.

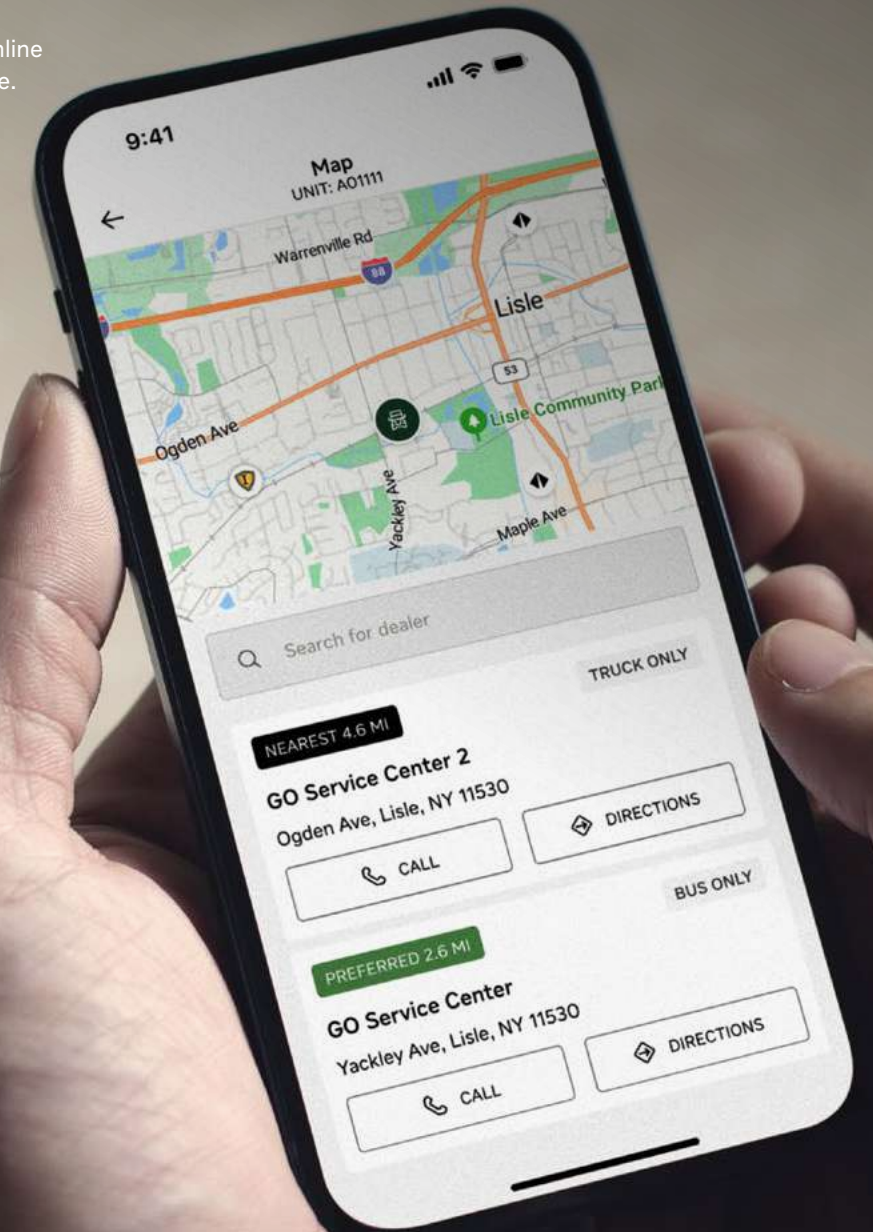

SERVICE COMMUNICATIONS WITH YOUR DEALER.

Our industry-leading service communications tool is designed to accelerate the repair process, streamline communications with your dealer service center and drive greater uptime.

FEATURES INCLUDE:

- Seamless communications with dealers, including service request initiation, up-to-date repair status, and estimate approvals
- Complete VIN-based information: asset specs, complete parts catalog, remote health data, and more
- Complete service history, up-to-date campaign information, and engine calibration status. Integration with parts inventory systems shows which dealer locations have the parts you need on the shelf now

5 YEARS ON US

- Service Communications is included for five years standard on new HV Series.

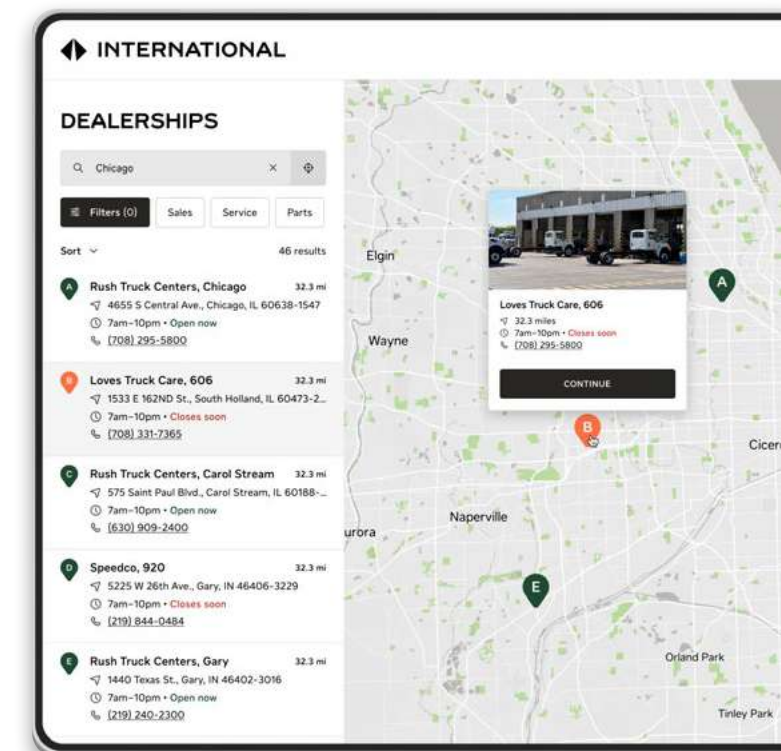

UNLOCK YOUR POTENTIAL.

International® Financial can help you take your business to the next level. We offer financing solutions for new and used International trucks and IC Bus® school buses, as well as used vehicles of all makes and models offered through International® Truck dealers, IC Bus dealers and International® Used Truck Centers.

As an expert in the commercial vehicle industry, we have a deep understanding of your wants and needs and are ready to help enable your success.

We offer flexible solutions to fit your truck, bus, vehicle or equipment financing needs, helping you secure the best financing products for your specific situation. Whether you're looking for a fleet vehicle loan or you need to lease fleet vehicles, our financial team can provide you with the best option suited to your business.



Internati

INTERNATIONAL TRUCK MO
1909-2024

| | | | |
|------|------------------|------|----|
| 1909 | AUTO WAGON | 1977 | S |
| 1913 | F SERIES | 1981 | C |
| 1934 | C SERIES | 1984 | 9 |
| 1937 | D SERIES | 1987 | 8 |
| 1938 | METRO | 1988 | 4 |
| 1941 | K SERIES | 1998 | 9 |
| 1941 | KB SERIES | 1999 | 5 |
| 1949 | L SERIES | 2000 | 9 |
| 1953 | R SERIES | 2001 | 4 |
| 1953 | V SERIES | 2001 | 7 |
| 1957 | A + B SERIES | 2002 | 8 |
| 1961 | SCOUT / SCOUT II | 2006 | PR |
| 1962 | LOADSTAR | 2008 | LO |
| 1963 | FLEETSTAR | 2016 | HX |
| 1968 | TRANSTAR | 2017 | HV |
| 1969 | D SERIES | 2017 | LT |
| 1970 | CARGOSTAR | 2017 | RH |
| 1971 | TRANSTAR 4200 | 2018 | MV |
| 1972 | PAYSTAR 5000 | 2018 | CV |

INTERNATIONAL TRUCKS
FROM THE FIELD TO THE FAST LANE
EST. 1902

THE CHOICE IS YOURS.

Fleet vehicle financing products have unique advantages and understanding those advantages can ensure your business selects the best financial solutions. The below comparison chart highlights the features and differences of our vehicle financing solutions.

| Loan vs. Lease Comparison ^{1,2} | Loan | Finance Lease | TRAC Lease ³ | Split TRAC Lease | FMV Lease |
|--|------|---------------|-------------------------|------------------|-----------|
| Flexible payment solutions | ✓ | | | | |
| No mileage restrictions | ✓ | ✓ | ✓ | | |
| Own equipment at end of term | ✓ | ✓ | ✓ | Optional | Optional |
| Finance lease for accounting purposes ² | | ✓ | ✓ | | |
| Lower payments | | | ✓ | ✓ | ✓ |
| Minimal initial cash outlay | | | | ✓ | ✓ |
| No purchase obligation at lease termination | | | | ✓* | ✓ |
| Operating lease for accounting purposes ² | | | | ✓ | ✓ |

1. International® Financial services are provided by Navistar Financial Corporation. Program eligibility, actual payments, terms and down payment are determined by Navistar Financial Corporation's credit team based upon creditworthiness of customer.

2. Navistar Financial Corporation does not provide or endorse any tax or accounting advice or tax strategy to its dealers, customers or potential customers. You should consult with your own tax and accounting advisor on all such matters relating to the loan or lease financings described in this brochure.

3. TRAC leases are limited to motor vehicles leased to businesses and must be used for commercial purposes at least 50% of the time.

* Lessor & Lessee take pro-rata portion of the estimated residual value risk.



We understand that your business depends on the reliability of your equipment. Our comprehensive ownership solutions provide greater productivity, efficiency and lower total cost of ownership for your fleet.

SERVICE CONTRACTS.

| Package Options | | Complete (Best Value) | Extended | Core |
|--------------------------|--|---|---|---|
| Maintenance and Service | <ul style="list-style-type: none"> Planned Maintenance Multi-point inspection Proactive Service Planning and Scheduling Customer Notifications Service Event Orchestration | <ul style="list-style-type: none"> ✓ ✓ ✓ ✓ ✓ | <ul style="list-style-type: none"> ✓ ✓ ✓ ✓ ✓ | <ul style="list-style-type: none"> ✓ ✓ ✓ ✓ ✓ |
| Powertrain Coverage* | <ul style="list-style-type: none"> Engine and Aftertreatment DEF System Transmission and Clutch | <ul style="list-style-type: none"> ✓ ✓ ✓ | <ul style="list-style-type: none"> ✓ ✓ ✓ | |
| Non-Powertrain Coverage* | <ul style="list-style-type: none"> Cooling and HVAC Starter / Alternator / Electrical Suspension and Steering Axles / Propshaft / Frame and Bumper Braking and Fuel Systems | <ul style="list-style-type: none"> ✓ ✓ ✓ ✓ ✓ | | |
| Towing Coverage | | Optional | Optional | Optional |

Coverage Term Options

- 3 Years / 300,000 Miles
- 4 Years / 100,000 Miles
- 5 Years / 100,000 Miles
- 5 Years / 300,000 Miles
- 5 Years / 500,000 Miles

Not all businesses have the same coverage requirements. Choose the package and term that suits your needs.

PLANNED MAINTENANCE

Consistent, high quality work performed with genuine OEM parts and lubricants that will keep your truck performing at its best. All backed by the industry's largest service network.

PROACTIVE SERVICE PLANNING

Using remote vehicle health and performance data, our team will support you with notifications for upcoming planned maintenance and service needs. By working with you to schedule this work in advance, the service location can be prepared for arrival and get your vehicle back in service as fast as possible.

SERVICE EVENT ORCHESTRATION

We offer resources dedicated to managing and expediting service and repair events, including reviewing repair history, ensuring calibrations are up to date, coordinating technical support when needed and providing timely communications and service product updates to keep you informed.

COMPLETE VEHICLE COVERAGE

Protect your vehicle's powertrain and other key components, including electrical, cooling, suspension systems, and more. Plans feature a guaranteed \$0 deductible, 100% parts and labor coverage, and NO claims maximums.

These service contracts are available at no financing cost. Ask your dealer about a payment program through International® Financial.

POWERFUL OPTIONS.

S13 INTEGRATED POWERTRAIN

| | |
|---------------------|---|
| Engine type | Diesel, 4-Cycle |
| Configuration | Inline 6-Cylinder |
| Displacement | 12.74L (777 cu. in.) |
| Bore & Stroke | 5.12 in. x 6.30 in. (126 mm & 166 mm) |
| Compression Ratio | 23:1 |
| Aspiration | Fixed Geometry Turbocharger |
| Combustion System | 1800 bar Common Rail |
| Engine Lubrication | 47.5 quarts (45L) |
| Total Engine Weight | 2,284 lbs. (1,036 kg) |
| Valves | 4 Valves per Cylinder, Dual Overhead Camshaft |
| B10 Design life | 1,200,000 mi (1,931,000 km) |

ENGINE WARRANTY

| | |
|--------------------------|---|
| Base Engine | 24 months; unlimited miles, unlimited hours* |
| Base Major Component | 60 months; 500,000 miles |
| Base Towing | 24 months; unlimited miles, unlimited hours** |
| Optional Engine | Up to 72 months, 600,000 miles |
| Optional Major Component | Up to 84 months, 700,000 miles |

* Fire & rescue applications: 60 months/100,000 miles/unlimited hours
**Towing for vehicles with engine failures

TRANSMISSION, CLUTCH AND TRANSMISSION MOUNTED PTO BASE WARRANTY (INCLUDES TOWING)

Less than 52K Rear Axles Rating: 3 years; unlimited miles

Greater than 52K Rear Axles Rating: 2 years; unlimited miles

T14 GEAR RATIOS AVAILABLE

| Gear | Ratio | Step | Gear | Ratio | Step | Gear | Ratio | Step |
|------|-------|------|------|-------|------|------|-------|------|
| R6 | 4.59* | - | 1 | 20.81 | 29% | 8 | 3.53 | 29% |
| R5 | 5.91* | - | 2 | 16.16 | 29% | 9 | 2.77 | 29% |
| R4 | 7.61* | - | 3 | 12.57 | 29% | 10 | 2.15 | 29% |
| R3 | 9.81* | - | 4 | 9.76 | 29% | 11 | 1.66 | 29% |
| R2 | 12.60 | - | 5 | 7.56 | 29% | 12 | 1.29 | 29% |
| R1 | 16.23 | - | 6 | 5.87 | 29% | 13 | 1.00 | 29% |
| | | | 7 | 4.55 | 29% | 14 | 0.78 | - |

HP RATING GOVERNED SPEED RPM TORQUE RATING (lb-ft @ RPM)

| | | |
|-----|------|------------|
| 370 | 2000 | 1250 @ 900 |
| 400 | 2000 | 1450 @ 900 |
| 430 | 2000 | 1550 @ 900 |
| 450 | 2000 | 1750 @ 900 |
| 475 | 2000 | 1750 @ 900 |
| 515 | 2000 | 1850 @ 900 |

CUMMINS B6.7 200-360* HP

| | |
|----------------------------|--------------------------------|
| Engine Type: | Diesel, 4-Cycle |
| Configuration: | Inline 6-Cylinder |
| Displacement: | 409 cu. in. (6.7L) |
| Bore and Stroke: | 4.21 X 4.88 in |
| Aspiration: | Variable Geometry Turbocharger |
| Combustion System: | Direct Injection |
| Engine Lubrication: | 15L |
| Total Engine Weight (Dry): | 1,150 lbs. |

HP RATING GOVERNED SPEED RPM TORQUE RATING (lb-ft @ RPM)

| | | |
|-----|------|------------|
| 200 | 2600 | 600 @ 1600 |
| 220 | 2600 | 600 @ 1600 |
| 240 | 2600 | 560 @ 1600 |
| 250 | 2600 | 660 @ 1600 |
| 260 | 2600 | 660 @ 1600 |
| 280 | 2600 | 660 @ 1600 |
| 300 | 2600 | 660 @ 1600 |
| 325 | 2600 | 750 @ 1800 |
| 340 | 2600 | 700 @ 1600 |
| 360 | 2600 | 800 @ 1800 |

CUMMINS L9 260-450* HP

| | |
|----------------------------|--------------------------------|
| Engine Type: | Diesel, 4-Cycle |
| Configuration: | Inline 6-Cylinder |
| Displacement: | 543 cu. in. (8.9L) |
| Bore and Stroke: | 4.49 X 5.69 in |
| Aspiration: | Variable Geometry Turbocharger |
| Combustion System: | Direct Injection |
| Engine Lubrication: | 15L |
| Total Engine Weight (Dry): | 1,695 lbs |

HP RATING GOVERNED SPEED RPM TORQUE RATING (lb-ft @ RPM)

| | | |
|-----|------|-------------|
| 260 | 2200 | 860 @ 1200 |
| 270 | 2200 | 860 @ 1200 |
| 300 | 2200 | 860 @ 1200 |
| 330 | 2200 | 1000 @ 1200 |
| 350 | 2200 | 1050 @ 1200 |
| 360 | 2200 | 1150 @ 1200 |
| 370 | 2100 | 1250 @ 1200 |
| 380 | 2100 | 1250 @ 1200 |
| 380 | 2100 | 1250 @ 1200 |
| 400 | 2200 | 1250 @ 1200 |
| 450 | 2100 | 1250 @ 1200 |

*Higher ratings limited to fire and rescue applications

DESIGNED FOR DRIVERS IN THE TOUGHEST APPLICATIONS – YOURS.



HV509 Regular Cab



HV509 Extended Cab



HV509 Crew Cab

Model Nomenclature Key

| Model Designation | Axle Configuration | BBC in inches | |
|-------------------|--------------------|---------------|-----|
| HV | 5 = Set-Forward | 109 | 115 |
| | 6 = Set-Back | 109 | 115 |

Example:
HV615 6x4 = Tandem drive,
115" BBC with Set-Back
front axle

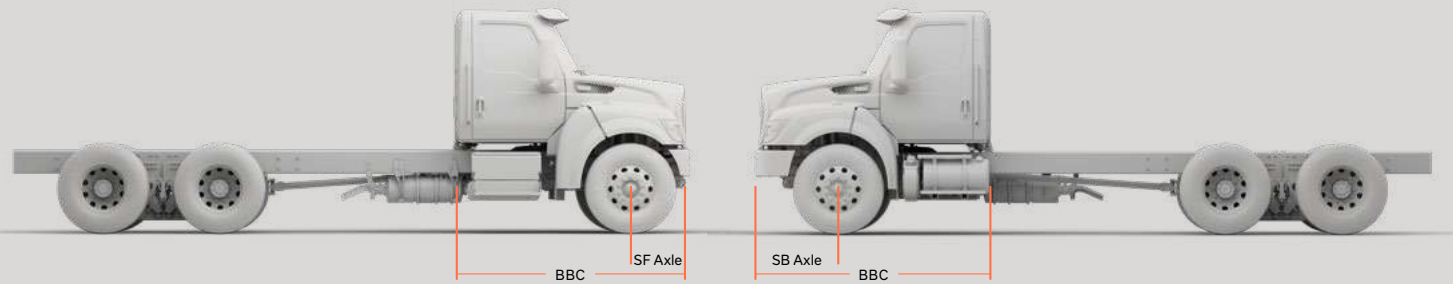

| Configuration | Model | Axles | Configuration | Model | Axles |
|------------------|-------|-------|---------------|-------|-------|
| Set-Forward Axle | HV509 | 4X2 | Set-Back Axle | HV609 | 4X2 |
| | | 4X4 | | | 6X4 |
| | | 6X4 | | | 4X2 |
| | | 6X6 | | | 6X4 |
| HV515 | 4X2 | HV615 | 6X4 | | |
| | 6X4 | | 8X6 | | |

109" BBC

| | |
|---------------------|---|
| GVW | 51,000 lbs. (4x4) (HV509) 53,000 lbs. (4x2) 66,000 lbs. (6x6) (HV509) 68,000 lbs. (6x4) |
| BBC/BA | 109" BBC / 40.3" BA (Day Cab) 109" BBC / 29.5" BA (Day Cab) |
| Cab Options | Day Cab / Extended Cab / Crew Cab |
| Wheelbase Options | 136" - 339" (HV509) 128" - 368" (HV609) |
| Axle Configurations | 4x2; 6x4 4x4 (HV509) 6x6 (HV509) |
| Rear Axle | Single Rear Axle (4x2) Cummins-Meritor • Single Reduction: 17,000 – 30,000 lbs. • Double Reduction: 30,000 – 38,000* lbs. • Two-Speed: 21,000 – 23,000 lbs. Dana Spicer • Single Reduction: 17,500 – 31,000 lbs. Tandem Rear Axle (6x4) Cummins-Meritor • Single Reduction: 40,000 – 46,000 lbs. Dana Spicer • Single Reduction: 46,000 lbs. |
| Front Axle | Cummins-Meritor • Non-Driving: 10,000 – 22,000 lbs. • Driving: 10,000 - 20,000 lbs. (HV509) Dana Spicer • Non-Driving: 10,000 – 20,000 lbs. |
| Frames | 11.25" x .5" thick super single rail Single Frame Rail Rating up to 3.3M in.-lbs. RBM and "C" Channel Reinforced Frame Rail Rating of 3.5M in.-lbs. RBM |
| Front Suspension | Spring Multi-leaf: 14,000 – 20,000 lbs. Parabolic Taper-leaf: 10,000 – 22,000 lbs. Auxiliary and Bias Springs Available |
| Rear Suspension | Chalmers: 23,000 – 46,000 lbs. Hendrickson • RT: 40,000 – 46,000 lbs. • HAS: 23,000 – 46,000 lbs. • HMX: 40,000 – 46,000 lbs. • PRIMAAX: 20,000 (HV509) 23,000 – 46,000 lbs. Link: 46,000 lbs. International: 20,000 – 40,000* lbs. Vari-Rate Springs: 18,500 – 31,000 lbs. |
| Electrical System | Alternators: 12 Volt, 160 – 325 Amp Battery Systems: 12 Volt, 1320 – 3800 CCA |
| Exhaust System | Frame Mounted Right Side, Back of or Under Cab Horizontal or Vertical Tailpipe Right Side Back of Cab |
| Brakes | Air Disc and Drum Brakes with ABS, Optional Traction Control, Optional Electronic Stability Program with Traction Control |
| Power Steering | Single Power Dual Power on Front Axle 16,000 lbs. and Above |
| Engines | Cummins B6.7: Up to 360** hp, 800 lb.-ft. of torque Cummins L9: Up to 450** hp, 1250 lb.-ft. of torque |
| Transmissions | Eaton Manual: 6, 8LL (10) and 13-speed Allison Automatic: 2500, 3000, 3500, 4000, 4500 (HS, EVS, RDS) |
| Fuel Tanks | 40 – 160 Gallons, Single or Dual, Non-Polished or Polished Aluminum, Mounted Right or Left Side Under Cab |
| Tires | Continental, Michelin, Goodyear, Bridgestone, Hankook |
| Safety | Fusion 3.0, Optional Data Recorder and Side Object Detection |

* Application restriction
**Higher ratings limited to fire and rescue applications

115" BBC

| | |
|---------------------|--|
| GVW | 60,000 lbs. (4x2) 74,000 lbs. (6x4) 75,000 lbs. (8x6) (HV615) |
| BBC/BA | 115" BBC / 46" BA (Day Cab) 115" BBC / 29.5" BA (Day Cab) |
| Cab Options | Day Cab / Extended Cab / Crew Cab |
| Wheelbase Options | 128" - 311" 4x2 152" - 311" 6x4 187" - 309" 8x6 |
| Axle Configurations | 4x2; 6x4 8x6 Tridem (HV615) |
| Rear Axle | Single Rear Axle (4x2) Cummins-Meritor • Single Reduction: 20,000 – 30,000 lbs. • Double Reduction: 30,000 – 38,000* lbs. • Two-Speed: 23,000 lbs. Dana Spicer • Single Reduction: 23,000 – 31,000 lbs. Tandem Rear Axle (6x4) Cummins-Meritor • Single Reduction: 40,000 – 52,000 lbs. Dana Spicer • Single Reduction: 46,000 – 50,000 lbs. Tridem Rear Axle (8x6) Cummins-Meritor • Single Reduction: 53,000 lbs. |
| Front Axle | Cummins-Meritor • Non-Driving: 12,000 – 22,000 lbs. Dana Spicer • Non-Driving: 12,000 – 23,000 lbs. |
| Frames | Single Frame Rail Rating up to 3.3M in.-lbs. RBM and "C" Channel Reinforced Frame Rail Rating of 3.5M in.-lbs. RBM |
| Front Suspension | Spring Multi-leaf: 14,000 – 20,000 lbs. Parabolic Taper-leaf: 12,000 – 23,000 lbs. Auxiliary and Bias Springs Available |
| Rear Suspension | Chalmers: 23,000 – 52,000 lbs. Hendrickson • RT: 40,000 – 46,000 lbs. • HAS: 23,000 – 46,000 lbs. • HMX: 40,000 – 46,000 lbs. (52,000 lbs. HV615) • PRIMAAX: 23,000 – 46,000 lbs. 69,000 lbs. (Tridem) • UMX: 46,000 – 52,000 lbs. (HV615) Link: 46,000 lbs. International: 20,000 – 40,000* lbs. |
| Electrical System | Alternators: 12 Volt, 160 – 320 Amp Battery Systems: 12 Volt, 1900 – 4600 CCA |
| Exhaust System | Single Dual-Stage After-Treatment Device, Single Horizontal or Vertical Tailpipe Right Side Back of Cab High Ground Clearance and Twin Steer Packaging Available |
| Brakes | Air Disc and Drum Brakes with ABS, Optional Traction Control, Optional Electronic Stability Program with Traction Control |
| Power Steering | Single Power Dual Power on Front Axle 16,000 lbs. and Above |
| Engines | International S13: 370 – 515 hp, 1,250 – 1,850 lb.-ft. of torque |
| Transmissions | International T14 Automated Manual 14-Speed with Two Crawler Gears and One Overdrive Gear Allison Automatic: 3000, 4000, 4500, 4700 (HS, EVS, RDS, OFS) |
| Fuel Tanks | 50 – 200 Gallons, Single or Dual, Non-Polished or Polished Aluminum, Mounted Right or Left Side Under Cab |
| Tires | Continental, Michelin, Goodyear, Bridgestone, Hankook |
| Safety | Fusion 3.0, Optional Data Recorder and Side Object Detection |



We understand making money means keeping your vehicles on the road.

That's why uptime is so important to us. Dependable equipment spec'd for your needs or requirements is just the beginning. We also focus on fuel economy, preventive maintenance, optimized service intervals and more to make sure the low cost of ownership of our vehicles helps keep you in the black.

Maximum Uptime Repair Before Failure

Prognostics move unplanned repairs to planned, optimizing maintenance using vehicle performance and predictive data.

Predictive Parts Stocking

Dealer parts inventory management uses AI and telematics data to predict stocking needs. This ensures the best parts are on dealer shelves to support customers.

Parts You Need Where and When You Need Them

Our partnership with Love's Truck Care & Speedco adds 400+ additional locations for quick, conveniently located access to light mechanical and select warranty work.*

International Dealer Locations

700

Love's Truck Care & Speedco Locations

400

Total Service Locations

1,100



TRUCK CARE

Find out more at
international.com

2701 International Drive
Lisle, IL 60532 USA



Note: The information and conclusions contained herein are believed to be correct at time of publication, but do not necessarily apply to similar vehicles with different specifications or with production dates after the production of this publication. Vehicles with different specifications or later dates of production may yield different results. Vehicle specifications are subject to change without notice. TAD17023 04/2025 ©2025 International Motors, LLC (d/b/a International Motors USA LLC in Illinois and Ohio). All rights reserved. All marks are trademarks of their respective owners.

