

LT<sup>®</sup> SERIES TRUCK

PRODUCT BROCHURE



# BAR RAISED. STANDARD SET.

THE INTERNATIONAL® LT® SERIES TRUCK

BUILT FOR THE ROAD AHEAD.

The world is changing. Technology is advancing. The powertrains of the future are all but determined. But the cargo that drives the economy of today still needs to be carried, goods still need to be delivered and businesses still need to run as efficiently as possible – now more than ever. And that is the core mission of the International® LT® Series truck equipped with the International® S13® Integrated Powertrain. It's a combination that delivers powerful performance with exceptional efficiency in a simple, easy-to-service design.



# IT ALL ADDS UP.

We went to great lengths to find efficiencies. Then we took it further.

The combination of the cab airflow upgrades with the International S13 Integrated Powertrain can achieve up to a 15% gain in fuel economy\* over the popular first-generation International A26. This is one reason why the International LT Series equipped with the S13 Integrated Powertrain is expected to set a new standard for the industry.

- Pedestal mirrors are optimized to reduce drag and wind noise.
- The 125" BBC hood is designed to smoothly direct airflow around the cab.
- Aerodynamic fender shape optimizes airflow.
- 25" cab extenders close the gap between cab and trailer to limit air turbulence.
- An aero-enhanced 3-piece bumper and front wheel openings are contoured to minimize resistance.
- Chassis skirts and cab closeouts are optimized to reduce aerodynamic drag.
- The cooling module is sealed to smooth airflow under the hood.
- The front air dam design reduces drag by efficiently pushing air down, under and around the truck.

**Aero package with chassis enablers**  
The airflow of the LT Series has been optimized through extensive wind tunnel research and computer simulations.



\*Comparing the fuel economy of the 2017 GHG International A26 engine in a 2017 International LT Series truck with aero package to the fuel economy of the new International S13 Integrated Powertrain in a 2024 International LT Series truck with the LT aero package and chassis enablers. Actual customer results may vary due to various factors, including but not limited to, truck specifications, weight of the vehicle, predictive features, environmental conditions, etc.

# AT THE HEART OF IT ALL.



Collaboration is a beautiful thing. By combining the best thinking with years of experience in a wide range of disciplines, you can reduce potential pitfalls and accelerate progress in uncharted territory. And just like the team who developed it, the International S13 Integrated Powertrain brings together three distinct entities – the S13 engine, the T14 transmission and the Dual Stage Aftertreatment Module – to create a whole.

# IT ALL COMES TOGETHER.

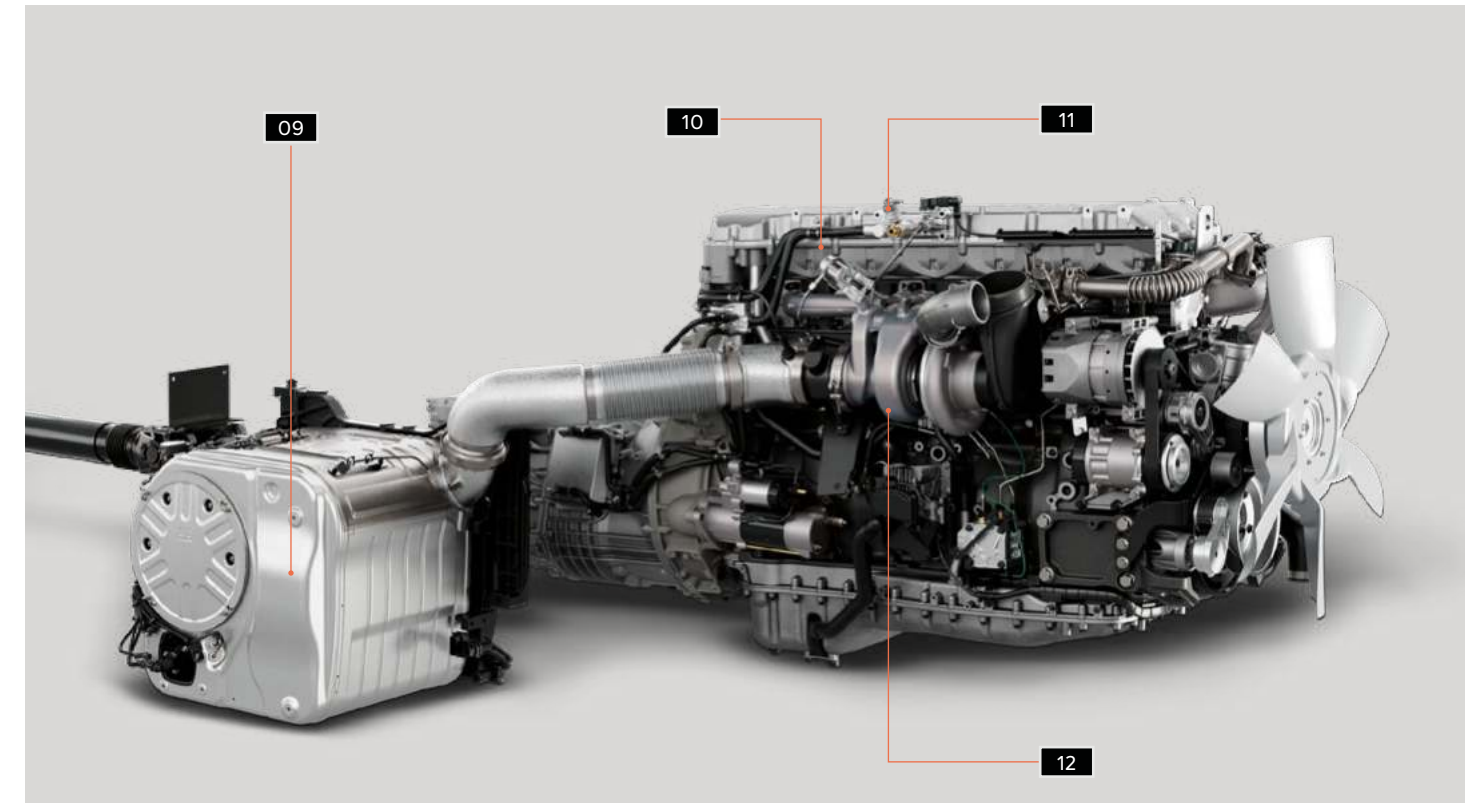
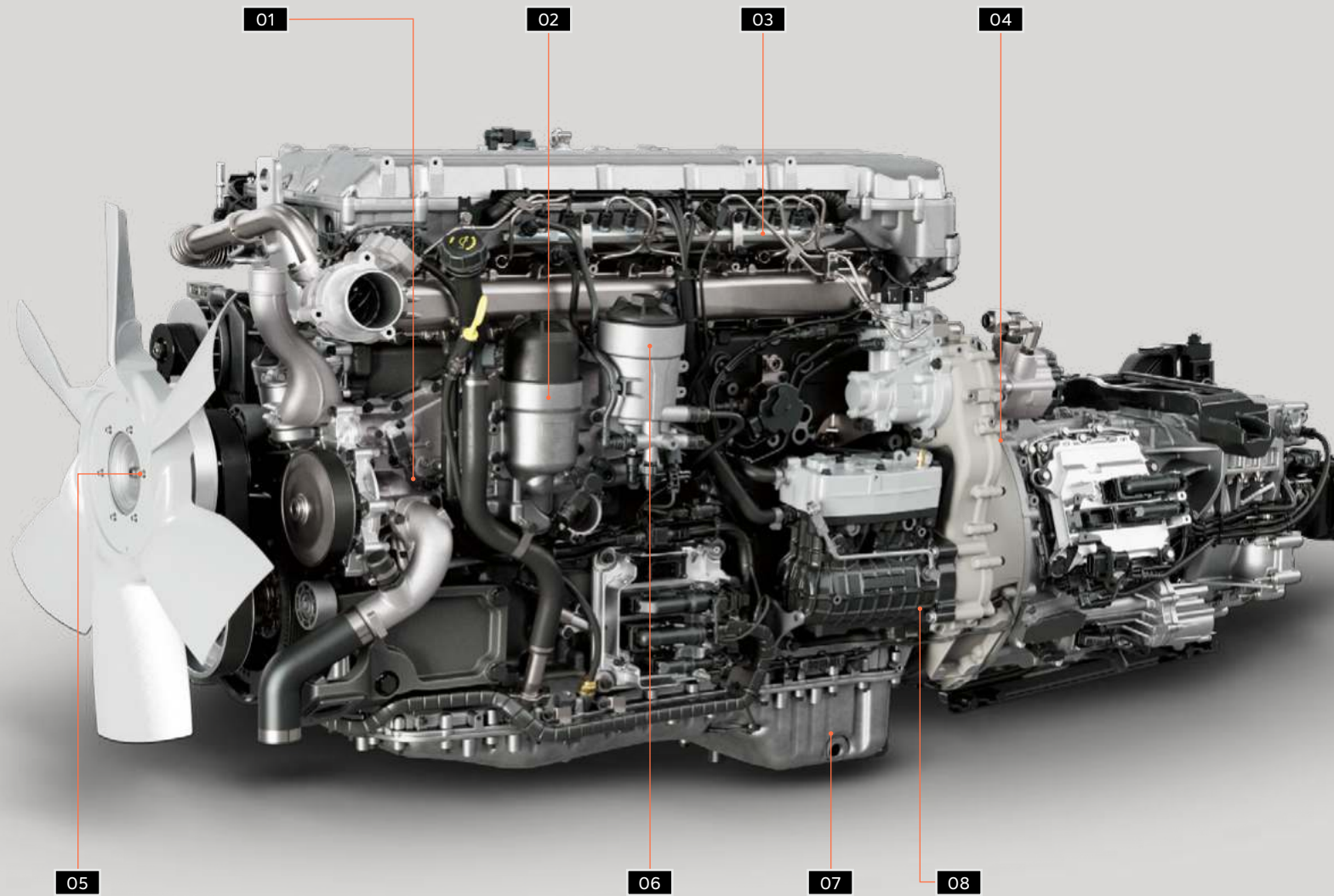

## PARTS AND SPECIFICATIONS

01	Water Pump	Low displacement, Low parasitic losses
02	Oil Filter	Cartridge style
03	High-Pressure Fuel System	1800 Bar
04	T14 Transmission	14-speed single countershaft geartrain transmission with wide ratio spread for efficiencies on flatlands and performance on hilly terrains
05	6- or 9-Blade Fan	For additional efficiency
06	Fuel Filter	
07	Oil Pan	Aluminum pan provides corrosion protection
08	Air Compressors	<ul style="list-style-type: none"> <li>• Single cylinder (iron)</li> <li>• Two cylinder (aluminum)</li> <li>• Two cylinder clutched (aluminum)</li> </ul>
09	Dual Stage After-Treatment	<ul style="list-style-type: none"> <li>• Compact design for more frame rail mounting space</li> <li>• No active DPF regen needed</li> </ul>
10	No Cooled EGR	EGR cooler not required with this advanced engine design
11	Aluminum Valve Cover	Rugged and lightweight
12	Fixed Geometry Turbo	More reliable and efficient design

By starting with a clean sheet of paper, our engineers behind the International S13 Integrated Powertrain were able to make sure the engine and transmission work in perfect harmony.

As a result, the fully automated T14 manual transmission shifts seamlessly and requires no input from the driver in terms of being in the right gear at the right time.

## SHIFT WHAT'S POSSIBLE.

### Transmission control module (TCM)

Predictive cruise control, neutral coast, downhill speed control, and predictive shifting can be found in one module - the TCM. Combining these features into one module means the vehicle feels more natural and intuitive and, ultimately, more efficient. The transmission has an electronically controlled clutch actuator that works in sync with the engine to deliver fast and smooth shifts. Since it does not consume air during complicated maneuvers, like when you're backing a trailer into a tight loading dock, the driver never needs to stop and let the air recharge.

### Driver shift modes

Three different shift modes (optional) for ultimate control for the driver

- **Economy** — Predictive shifting with fuel efficiency focus
- **Performance** — Perfect balance
- **Performance+** — Shifting at peak power with focus on performance

### Precision maneuvering mode

This mode gives the driver more control of the vehicle at low speeds for specific movements, such as reversing into a loading dock, connecting to a trailer or navigating a crowded construction site. Torque value for pedal input is reduced. This mode allows the clutch to slip more easily for slow and smooth performance.

### Eco-coast

Eco-coast disengages the driveline when traveling downhill, using the momentum of the vehicle to save fuel.

### Creep mode

This mode allows the vehicle to automatically start moving when the brake pedal is released while the transmission is in gear. This mode is useful in high traffic and other events where constant vehicle movement is necessary without the use of the accelerator pedal.

### Downhill speed control

Downhill speed control functions like cruise control without acceleration. When descending a grade, the driver can use this to maintain a set speed.

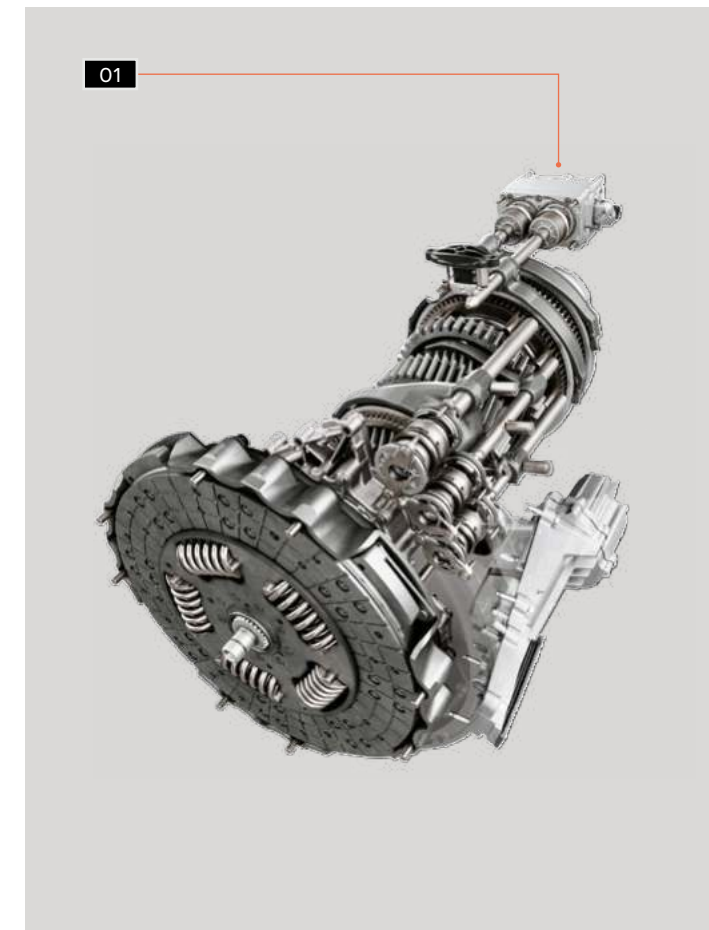

## T14 MANUAL TRANSMISSION PARTS AND FEATURES

01	Shift actuators	Shift actuator packaging was designed specifically for automated functionality (rather than adapted from a manual), allowing for more compact gearbox housing
02	Variable oil level Upper reservoir	Oil is pumped to the reservoir under lower loads to reduce parasitic losses, allowing for the continuous lubrication of gears by the oil sprayers
03	Planetary gears	The planetary gear set eliminates the need for a dedicated reverse gear, shortening the gearbox and allowing for better packaging within the chassis
04	Single countershaft	A single countershaft with helical gears lowers the overall weight of the unit without compromising the durability or performance of the transmission

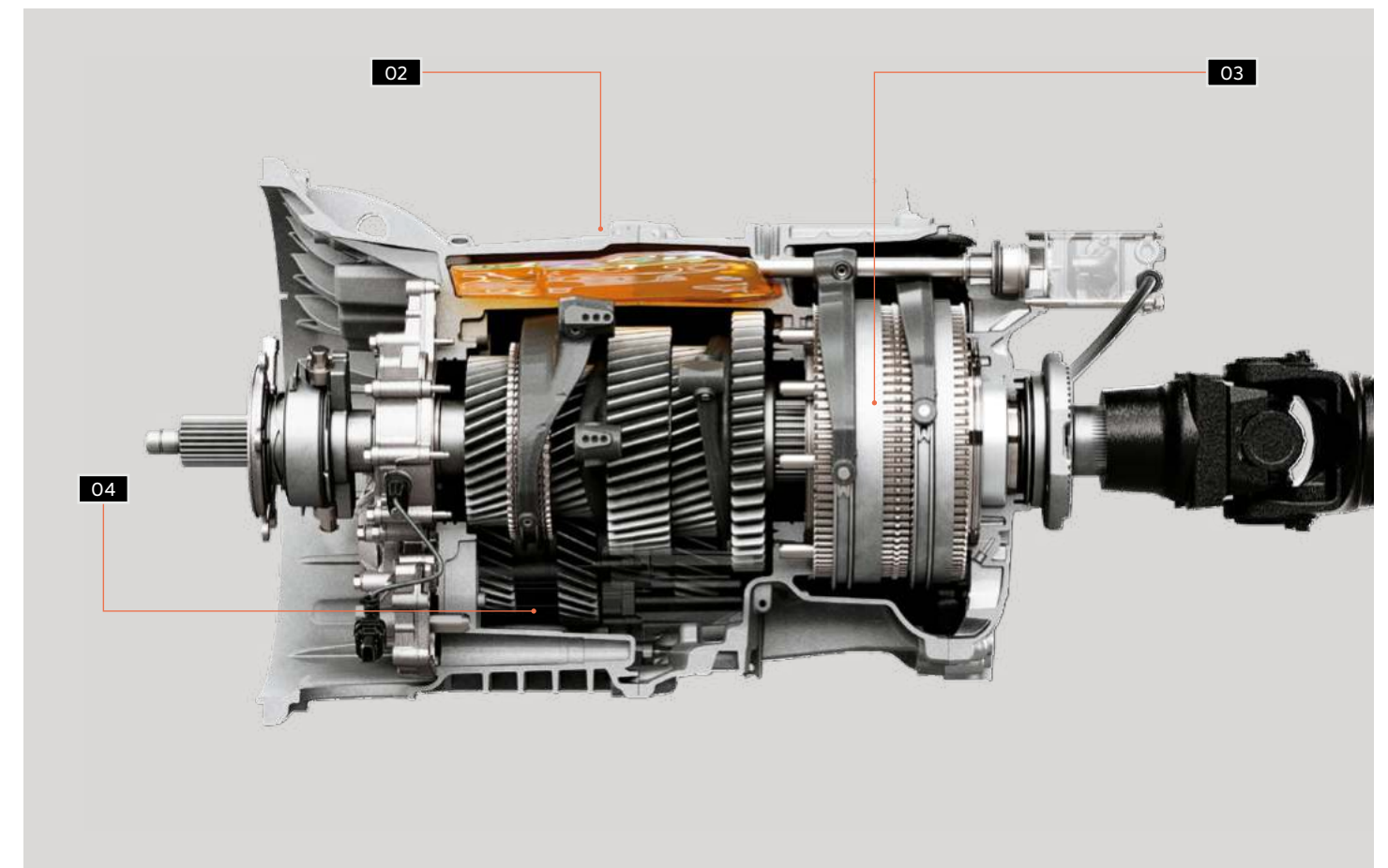

## DRIVERFIRST™

The International LT Series is a truck that drivers want to drive. To achieve this, we turned to the people who know driving best — real truck drivers. These professionals gave us honest, priceless input during numerous research sessions and driver clinics. Then we set about redesigning, fine-tuning and retesting until drivers agreed, “This is the truck I’ve always wanted to drive.” That’s how the LT Series became the most driver-centric truck on the road today. It has more intuitive controls, enhanced visibility, a quieter cab, critical information at your fingertips and dozens of other smart features that help keep a driver comfortable and in control over the long haul.



LISTENING AND DELIVERING.

Every detail inside the International LT Series cab has been carefully designed, measured and clinic-tested to optimally benefit the driver. The gauges received numerous tests and refinements to optimize their readability, usability and positioning, so key information and alerts are precisely where they need to be to view without distraction. The standard premium gauge cluster features a customizable digital display that lets drivers intuitively select the information they prefer in a variety of situations.



## INTEL THAT'S RELEVANT, INTUITIVE AND CUSTOMIZABLE.



The premium gauge cluster includes a customizable digital display that provides a wealth of information for the driver, including:

Real-time fuel economy

Axle load\*

Custom gauge settings\*

Safety indicators\*

Digital speedometer

Tire pressure\*

\*When added with optional feature code for required sensors

# TAILOR THE LT SERIES TO SUIT YOUR DRIVER AND FIT YOUR BUSINESS.

## CLASSIC

Door Trim	Easy-to-Clean, Soft Touch Vinyl
Trim Inserts	Neutral
Instrument Panel	Black
Gauge Cluster	8-Gauge, 3.5" Display with Odometer and Trip Optional: Premium 8-Gauge, 5" Color Display with Virtual Gauges
Accent Color	Neutral
Sun Visors	2
Lighting	LED
Window Controls	Power
Lock Controls	Manual or Power
Cup/Bottle Holders	4

## DIAMOND

Door Trim	Easy-to-Clean, Soft Touch Vinyl
Trim Inserts	Neutral
Instrument Panel	Black
Gauge Cluster	8-Gauge, 3.5" Display with Odometer and Trip Optional: Premium 8-Gauge, 5" Color Display with Virtual Gauges
Accent Color	Neutral
Sun Visors	2
Lighting	LED
Window Controls	Power
Lock Controls	Manual or Power
Cup/Bottle Holders	4

## DIAMOND ELITE

Door Trim	Easy-to-Clean, Soft Touch Vinyl
Trim Inserts	Neutral
Instrument Panel	Black
Gauge Cluster	8-Gauge, 3.5" Display with Odometer and Trip Optional: Premium 8-Gauge, 5" Color Display with Virtual Gauges
Accent Color	Neutral
Sun Visors	2
Lighting	LED
Window Controls	Power
Lock Controls	Manual or Power
Cup/Bottle Holders	4



# SLEEPER FEATURES.

Not all trips require the same amount of bunk space. In fact, some trucks may be operated by one driver on the way out and two drivers on the way back.

The flip-up (upper) bunk allows the driver to simply raise the extra bunk and enjoy the wide open space.

SLEEPER FEATURES	CLASSIC	DIAMOND	DIAMOND ELITE
12-Volt Power Supply	Standard	Standard	Standard
Trim Panels	Easy-to-Clean, Soft Touch Vinyl Neutral Trim Panels	Easy-to-Clean, Soft Touch Vinyl with Mineral Grey Teak Accents	Easy-to-Clean, Soft Touch Vinyl with Satin Mahogany Accents
Headliner	Soft Vinyl	Soft Vinyl	Soft Vinyl
Sleeper Windows	Standard	Standard	Standard
Windshield Curtain	Optional	Optional	Optional
Sleeper Control Panel	Standard	Standard	Standard
Microwave Accommodation	Optional	Optional	Optional
TV Accommodation	Optional	Optional	Optional

## 56" LOW-ROOF

Overhead Storage	Two Airline-Style Cabinets Standard, with an Option for Two Additional	Two Airline-Style Cabinets Standard, with an Option for Two Additional	Two Airline-Style Cabinets Standard, with an Option for Two Additional
------------------	--	--	--

## 56" HI-RISE

Overhead Storage	Two or Four Compartments with Netting	Two Compartments with Netting or Doors	Two Compartments with Netting or Doors
Rear Wall Storage	Optional	Optional	Optional

## 73" HI-RISE

Overhead Storage	Optional Two or Four Compartments with Nets or Optional Doors	Optional Two or Four Compartments with Nets or Optional Doors	Optional Two or Four Compartments with Nets or Optional Doors
Rear Wall Storage	Optional	Standard	Standard
Driver Side Wardrobe	Standard, Optional Doors	Standard, Optional Doors	Standard, Optional Doors
Passenger Side Cabinets	Utility Cabinet, Lower Right Wardrobe Tower Cabinet, Dresser Cabinet, Refrigerator, Storage with or without Doors	Utility Cabinet, Lower Right Wardrobe Tower Cabinet, Dresser Cabinet, Refrigerator, Storage with or without Doors	Utility Cabinet, Lower Right Wardrobe Tower Cabinet, Dresser Cabinet, Refrigerator, Storage with or without Doors

## 73" SKY-RISE

Overhead Storage	Two Compartments with Nets	Two Compartments with Nets	Two Compartments with Nets
Rear Wall and Upper/Lower Storage	Standard	Standard	Standard
Driver Side Cabinets	Standard Lower and Upper Storage with Shelves, Nets or Optional Door	Standard Lower and Upper Storage with Shelves, Nets or Optional Door	Standard Lower and Upper Storage with Shelves, Nets or Optional Door
Passenger Side Wardrobe	Standard Cabinet Tower Wardrobe and Optional Door, Shelves and Net	Standard Cabinet Tower Wardrobe and Optional Door, Shelves and Net	Standard Cabinet Tower Wardrobe and Optional Door, Shelves and Net

# DESIGNED WITH FLEETS IN MIND.



Fits in to your fleet like your favorite pair of work gloves

The International LT Series was engineered to seamlessly integrate into fleets of all sizes. Not only can fleets benefit from exceptional fuel economy, but they also get extended service intervals to keep their equipment on the road, plus the largest service network in the industry for convenient access to white glove treatment from ASE Certified technicians. All LT Series powertrains are designed to work seamlessly with Advanced Remote Diagnostics, which has helped some fleets reduce vehicle failures requiring a tow by up to 80%.

#### **Fleet friendly**

- Largest North American service network in the industry (with Love's network)
- Single point of service for vehicle and powertrain
- Extended service/maintenance intervals
- Wide selection of warranty and extended service contracts

# A VISION FOR SAFETY.

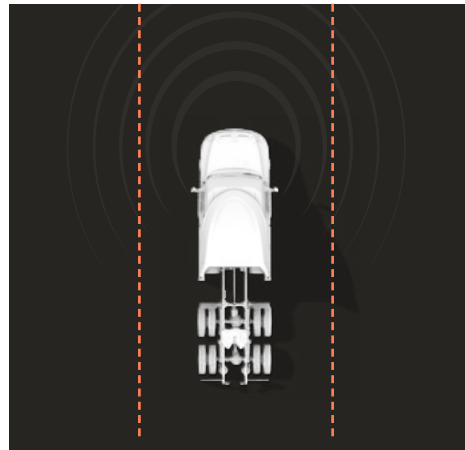

## BENDIX® WINGMAN® SYSTEMS

The optional Bendix® Wingman® Advanced™ and Bendix Wingman collision mitigation systems can greatly enhance operator safety. By integrating adaptive cruise control, lane departure warning, over-speed alert and stationary vehicle braking, these cutting-edge systems can help the driver potentially avoid a collision or help reduce its severity.

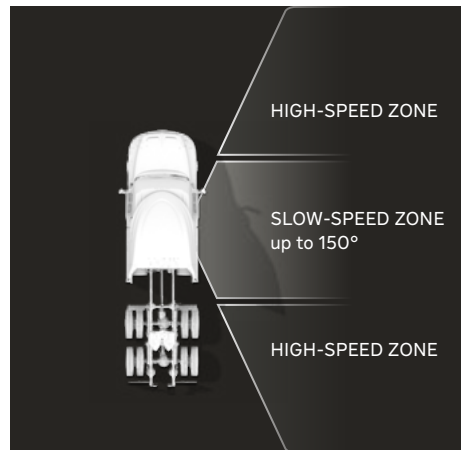

## BENDIX® BLINDSPOTTER®

When connected to the vehicle's Control Area Network (CAN), the optional Bendix® BlindSpotter® provides a 150° range of coverage, capable of detecting objects up to 20 feet in front of and 20 feet behind the BlindSpotter radar. The coverage zone extends up to 10 feet to the right of the vehicle. BlindSpotter minimizes false alerts by operating in two modes: highway speeds and lower speeds.



## LED HEADLIGHTS

LED headlights offer unparalleled nighttime visibility for improved safety, whether you're inside the cab or out.

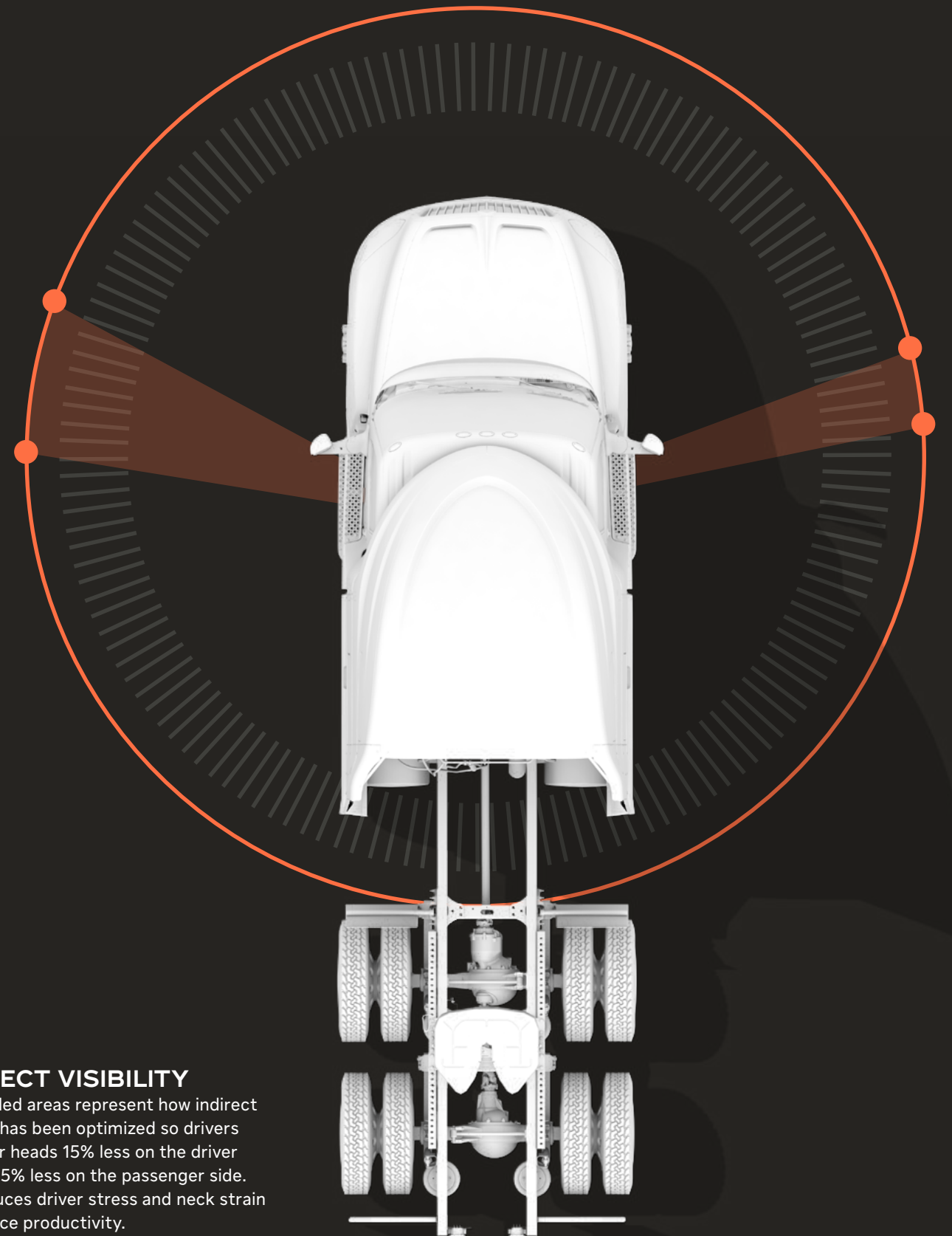

## INDIRECT VISIBILITY

The shaded areas represent how indirect visibility has been optimized so drivers turn their heads 15% less on the driver side and 5% less on the passenger side. This reduces driver stress and neck strain to enhance productivity.

# SIMPLIFYING MAINTENANCE TO MAXIMIZE UPTIME.

The faster your truck can be serviced, the faster you can get back on the road, meeting delivery schedules and boosting your profitability.

The International LT Series is designed and engineered to optimize uptime with industry-leading serviceability. All key service points under the hood, inside the cab, and around the vehicle are ergonomically designed for easy access. Many components are engineered with longer intervals between required maintenance. And when you do need service, you can count on expert technicians and an extensive parts inventory from your International dealer.

## KEEPING YOU ON THE ROAD TO PROFITABILITY.

- Standard LED headlamps and fog lamps deliver a bright light pattern. Tough polycarbonate lenses protect against breakage.
- Driver controls and instrumentation are based on robust industry-standard SAE J1939 electrical architecture, with gauge cluster and switches designed to keep drivers focused.
- The HVAC max defrost feature helps clear windows faster in colder climates, providing quicker, clearer visibility for increased uptime and less waiting.
- Standard Intelligent Fleet Care provides an intuitive preventive maintenance solution with fleet health monitoring, advanced fuel analytics and TPMS integration.
- Cab wiring features a power distribution module that's located inside the cab, protected from the elements.
- ChemGuard coating under the cab floor provides additional corrosion protection.
- All brake life servicing intervals are aligned, reducing maintenance events and expense.

The advanced International S13 Integrated Dual Stage Aftertreatment system eliminates the need for an EGR cooler and diesel oxidation catalyst.



The LT Series hood opens wide and features gas strut control and torsion bar lift assist. The torsion bar reduces opening effort and enables the hood to be lifted with one hand. The gas strut helps dampen closing to prevent the hood from closing too quickly.

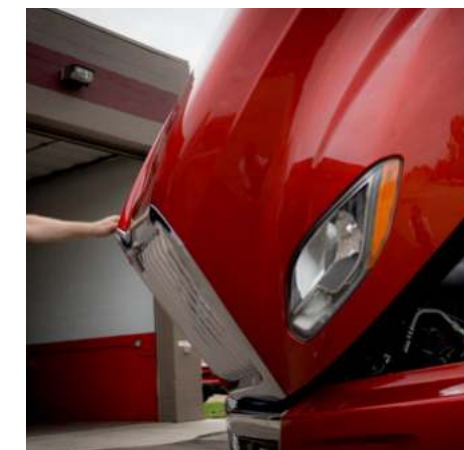

Translucent containers allow you to check fluid levels at a glance. Tethered caps on most fluid containers prevent dropped or lost caps while refreshing fluids.

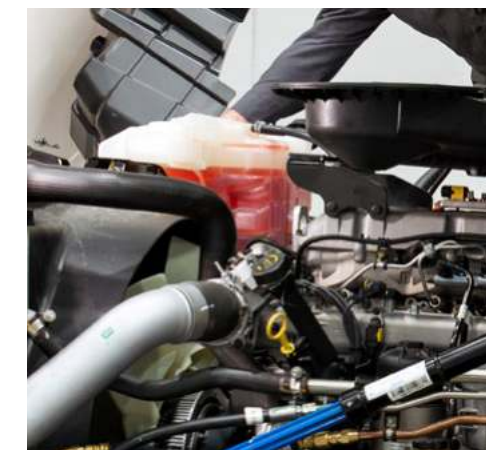

# LT SERIES CONFIGURATIONS



01

01	73" Sky-Rise Sleeper	125" BBC Long Haul and Owner-Operator
02	Day Cab	125" BBC Local, Regional, Bulk, and Specialized Applications
03	56" Low Roof Sleeper	125" BBC Regional Line Haul, Bulk, Flatbed, and Specialized Applications
04	56" Hi-Rise Sleeper	125" BBC Regional Line Haul and Owner-Operator
05	73" Hi-Rise Sleeper	125" BBC Long Haul Flatbed, Owner-Operator and Specialized Applications



02

03

04

05

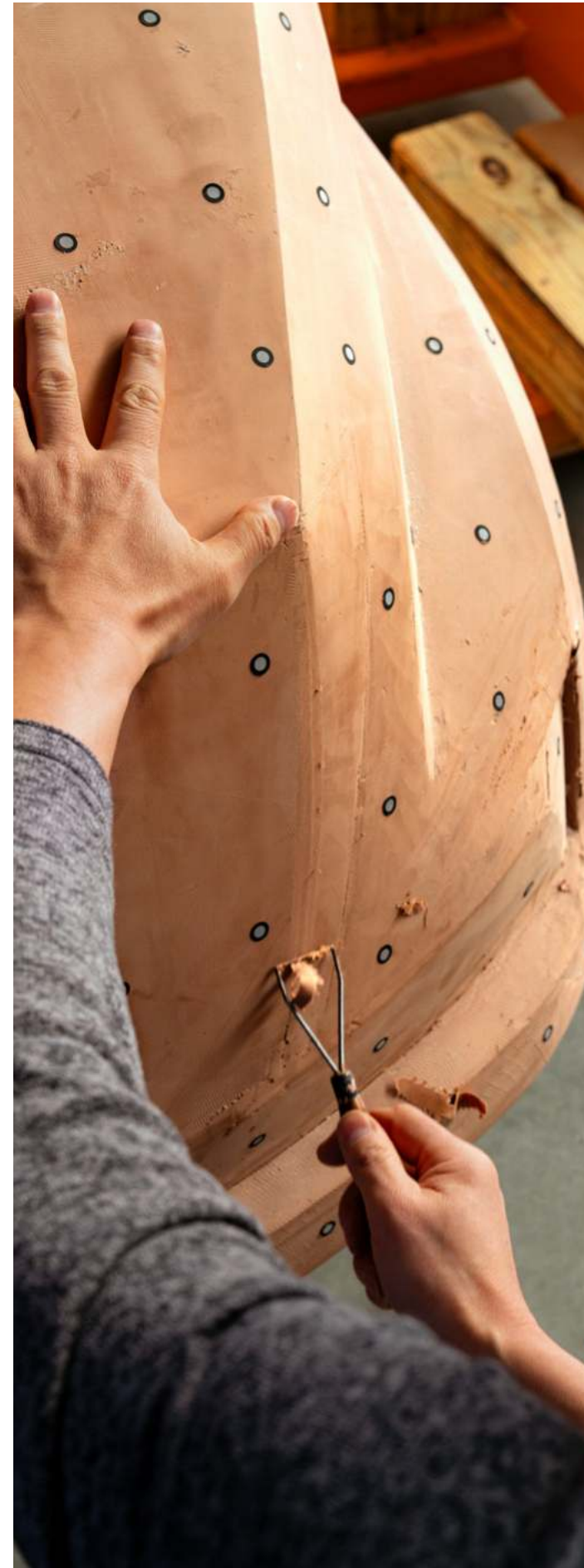

# LT SERIES SPECIFICATIONS

BBC/BA	125" BBC / 50" BA
Cab Configurations	Day Cab 56" Low Roof Sleeper 56" Hi-Rise Sleeper 73" Hi-Rise Sleeper 73" Sky-Rise Sleeper
Axle Configurations	4x2 6x2 6x4
Frames	Heat-Treated Alloy Steel 120,000 PSI
Engines	International® S13 12.74L • 400 – 515 hp • 1,450 – 1,850 lb.-ft. Cummins® X15 15L • 400 – 565 hp • 1,450 – 2,050 lb.-ft.
Transmissions	Automated Manual Transmissions • International® T14: 14-speed • Eaton Cummins Endurant: 11, 12 speed Manual Transmissions • Eaton Fuller: 10 speed • Fuller: 10, 13, 18 speed
Front Axles	Hendrickson: 12,350 – 14,000 lbs. Dana Spicer: 12,350 – 14,000 lbs. Cummins-Meritor: 12,350 – 14,000 lbs.
Front Suspension	Spring Monoleaf: 12,350 – 13,200 lbs. Parabolic Taperleaf: 12,350 – 14,000 lbs.
Single Rear Axles	Cummins-Meritor: 23,000 lbs. Dana Spicer: 23,000 lbs.
Tandem Rear Axles	Cummins-Meritor: 40,000 – 46,000 lbs. Dana Spicer: 40,000 – 46,000 lbs.
Rear Suspensions	Air Single • International®: 20,000 lbs. Air Tandem • International: 40,000 lbs. • Hendrickson: HAS 40,000 – 46,000 lbs.
Brakes	Air Drum Brakes with Automatic Traction Control and Electronic Stability Control  Air Disc Brakes with Automatic Traction Control and Electronic Stability Control
Interior Trim Levels	Classic Diamond Diamond Elite

# S13 INTEGRATED T14 TRANSMISSION

## S13 INTEGRATED

Engine type	Diesel, 4-Cycle
Configuration	Inline 6-Cylinder
Displacement	12.74L (777 cu. in.)
Bore & Stroke	5.12 in. x 6.30 in. (126 mm & 166 mm)
Compression Ratio	23:1
Aspiration	Fixed Geometry Turbocharger
Combustion System	1800 bar Common Rail
Engine Lubrication	47.5 quarts (45L)
Total Engine Weight	2,284 lbs. (1,036 kg)
Valves	4 Valves per Cylinder, Dual Overhead Camshaft
B10 Design life	1,200,000 mi (1,931,000 km)

## INDUSTRY-LEADING ENGINE WARRANTY

Base Engine	24 months; unlimited miles, unlimited hours*
Base Major Component	60 months; 500,000 miles
Base Towing	24 months; unlimited miles, unlimited hours**
Optional Engine	Up to 72 months, 600,000 miles
Optional Major Component	Up to 84 months, 700,000 miles

## T14 TRANSMISSION

Deep low-end gearing and shifting smoothness, delivering efficiencies of a direct drive in an overdrive package

14-speed with crawler gears

A lightweight, efficiently packaged and robustly designed gearbox with unlimited GCW

Single countershaft transmission designed for simplicity and reliability

## TRANSMISSION BASE WARRANTY (INCLUDES TOWING)

Transmission	60 months; 750,000 miles (1,200,000 km)
Clutch	36 months; 350,000 miles (563,000 km)

## GEAR RATIO

Gear	Ratio	Step	Gear	Ratio	Step	Gear	Ratio	Step
R1	12.60	-	5	7.56	29%	11	1.66	29%
R2	16.23	-	6	5.87	29%	12	1.29	29%
1	20.81	29%	7	4.55	29%	13	1.00	29%
2	16.16	29%	8	3.53	29%	14	0.78	28%
3	12.57	29%	9	2.77	29%			
4	9.76	29%	10	2.15	29%			

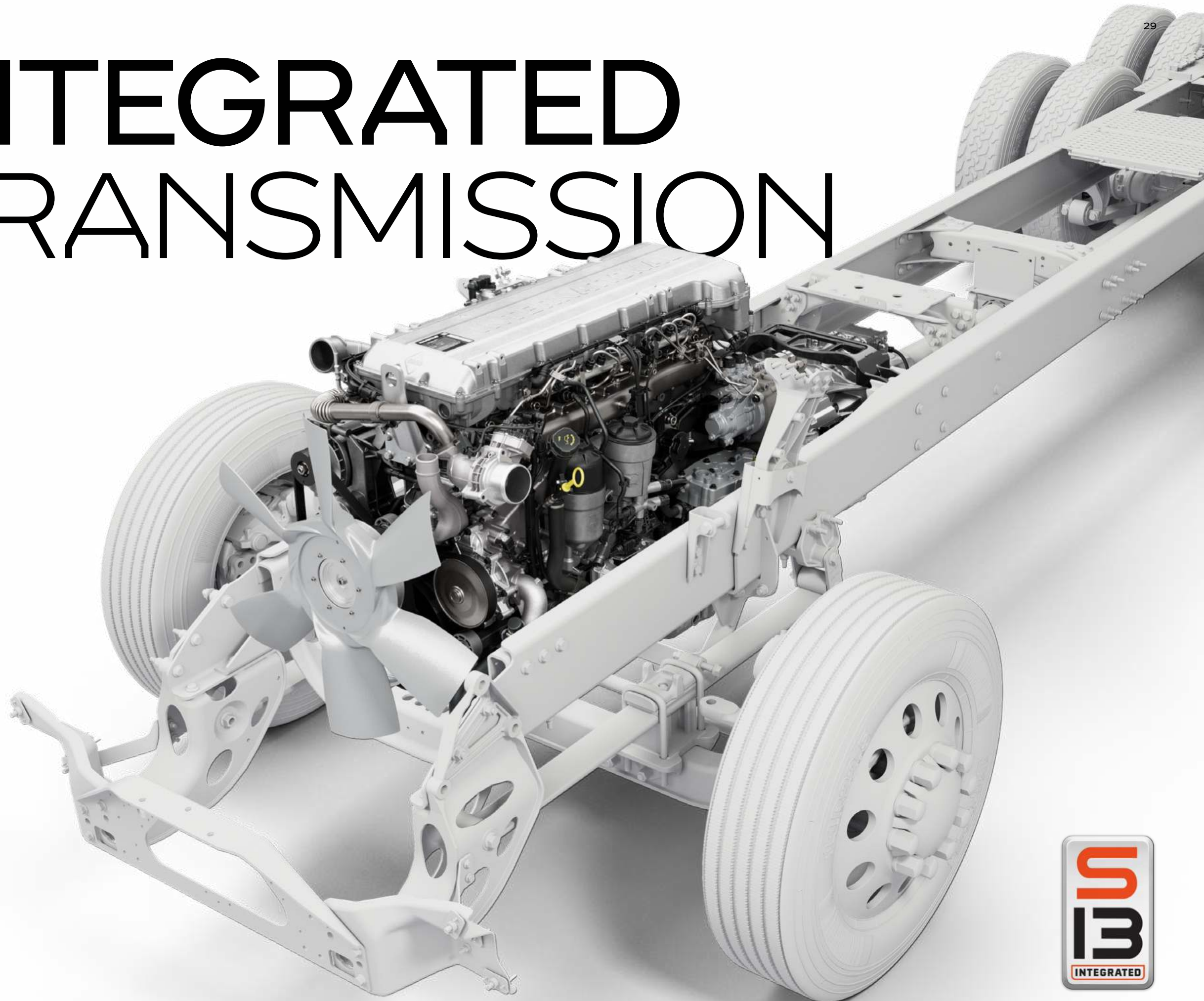



# POWERHOUSE PERFORMER.

## CUMMINS X15 LONG-HAUL MUSCLE

Cummins power in the X15 Productivity, Performance and Efficiency Series configurations. The X15 Efficiency Series produces up to 500 hp with advanced fuel-saving technology that includes dynamic electronic controls with ADEPT features, enhanced engine breathing and an optimized combustion process that leverages Cummins' proprietary VGT™ Turbo and XPI fuel system.



### Variable Geometry Turbocharger

Titanium compressor wheel provides excellent longevity. Serviceable electronic actuator increases uptime and reduces service cost.

### Jacobs Engine Brake®

Variable Geometry Turbocharger improves engine braking performance, particularly at low to mid-RPMs and higher altitudes.

### 2500 Bar High-Pressure Common Rail Fuel System

Delivers maximum fuel injection pressure (36,300 psi) to reduce emissions and fuel consumption, with multiple injection events for smooth and quiet operation.

### Lightweight design

Compacted Graphite Iron crankcase, shot-peened aluminum flywheel housing, composite valve covers and a hollow camshaft deliver a lightweight design, maximizing payload capacity.

### Cold starting

Cold starting down to -40°F with available oil heater, coolant heater and cold start system with unaided cold starting down to 10°F for dependable starting in extreme conditions.

Engine Type	Diesel, 4-Cycle
Configuration	Inline 6-Cylinder
Displacement	14.9L (912 cu. in.)
Bore & Stroke	5.3 in. & 6.65 in. (137 mm & 169 mm)
Compression Ratio	18.9:1
Aspiration	Variable Geometry Turbocharger
Combustion System	Direct Injection CPI Fuel System
Engine Lubrication	56 Quarts (53L)
Total Engine Weight	2,961 lbs. (1,343 kg)
Valves	4 Valves per Cylinder, Single Overhead Camshaft
B10 Design Life	1,000,000 mi (1,609,000 km)

LISLE, ILLINOIS  
USA  
*International*  
FROM THE FIELD  
TO THE FAST LANE  
EST. 1902

# OWNERSHIP SUPPORT.

- Connected Vehicle Services
- Service Communications
- International™ Financial
- Service Contracts

International is the first and only OEM to create connected solutions built for how you do business - designed on an open architecture, integrated with over 30 third party telematics providers, and compatible with all makes and models.\*

## INDUSTRY-LEADING CONNECTIVITY.

Take your performance to the next level. Our connected vehicle technology includes tools designed to give your business and operations that extra edge.

### 5 Years On Us

Factory installed telematics and five years of connected vehicle services are standard on new LT Series trucks.

### OTA Programming

Ensure peak performance with remote software calibration and programmable parameter updates to the International® S13 Integrated Powertrain — anytime, anywhere.

### Fleet Health Monitoring

Weekly reports on vehicles showing fault codes that are most likely to suggest a risk of roadside failure.

### Gateway Integrations

Our factory installed telematics system can connect you to select fleet management and compliance software providers seamlessly, without the cost and complexity of additional hardware installation on your vehicle.

\* For most commercial vehicles powered by diesel engines, 2007 MY and later.

### Our Advanced Remote Diagnostics platform features:

- Reports on vehicle health issues that include severity ratings, likely needed parts and service, and recommended actions.
- Comprehensive vehicle health reports that include performance data, fault history and more.
- Up-to-date GPS location with customizable geofencing reports that can help ensure vehicles are where they need to be.
- Insights delivered how you need it — via our online portal, your email inbox, a mobile app and more.

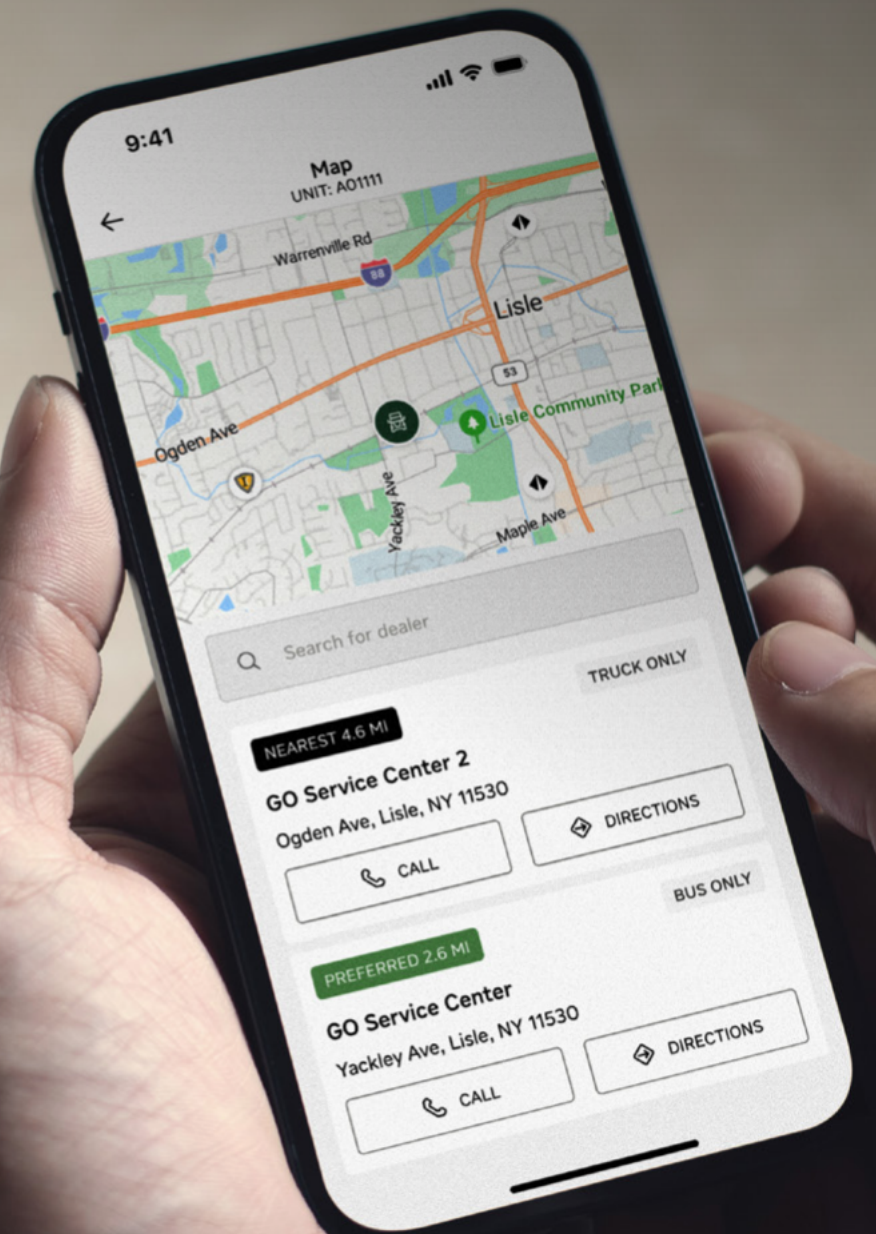

# SERVICE COMMUNICATIONS WITH YOUR DEALER.

Our industry-leading service communications tool is designed to accelerate the repair process, streamline communications with your dealer service center and drive greater uptime.

## FEATURES INCLUDE:

- Seamless communications with dealers, including service request initiation, up-to-date repair status, and estimate approvals
- Complete VIN-based information: asset specs, complete parts catalog, remote health data, and more
- Complete service history, up-to-date campaign information, and engine calibration status. Integration with parts inventory systems shows which dealer locations have the parts you need on the shelf now

## 5 YEARS ON US

- Service Communications is included for five years standard on new LT Series trucks.

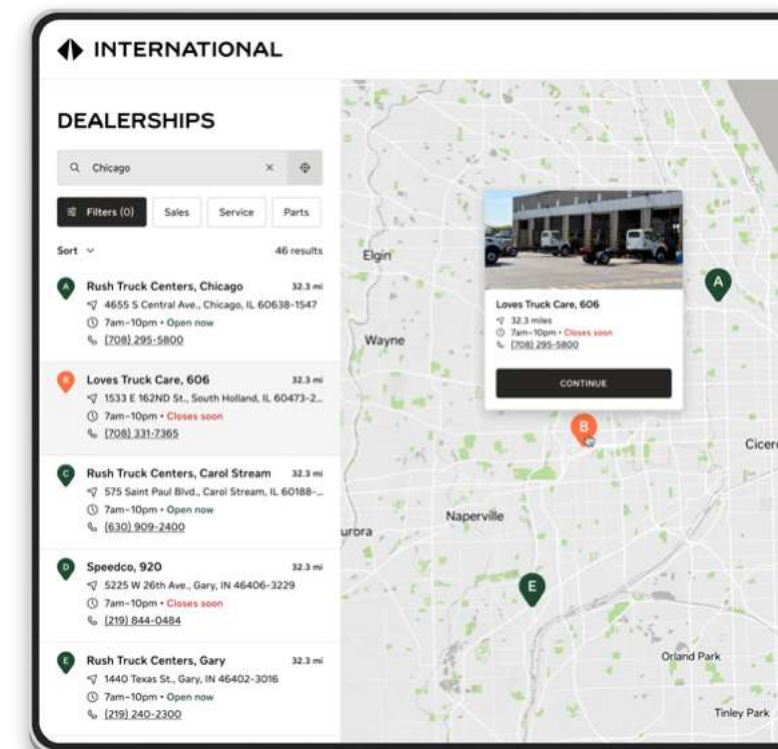

# UNLOCK YOUR POTENTIAL.

International® Financial can help you take your business to the next level. We offer financing solutions for new and used International® trucks and IC Bus® school buses, as well as used vehicles of all makes and models offered through International® Truck dealers, IC Bus dealers and International® Used Truck Centers.

We offer flexible solutions to fit your truck, bus, vehicle or equipment financing needs, helping you secure the best financing products for your specific situation. Whether you're looking for a fleet vehicle loan or you need to lease fleet vehicles, our financial team can provide you with the best option suited to your business.

As an expert in the commercial vehicle industry, we have a deep understanding of your wants and needs and are ready to help enable your success.

## THE CHOICE IS YOURS.

Fleet vehicle financing products have unique advantages and understanding those advantages can ensure your business selects the best financial solutions. The below comparison chart highlights the features and differences of our vehicle financing solutions.

Loan vs. Lease Comparison <sup>1,2</sup>	Loan	Finance Lease	TRAC Lease <sup>3</sup>	Split TRAC Lease	FMV Lease
Flexible payment solutions	✓				
No mileage restrictions	✓	✓	✓		
Own equipment at end of term	✓	✓	✓	Optional	Optional
Finance lease for accounting purposes <sup>2</sup>		✓	✓		
Lower payments			✓	✓	✓
Minimal initial cash outlay				✓	✓
No purchase obligation at lease termination				✓*	✓
Operating lease for accounting purposes <sup>2</sup>				✓	✓

1. International™ Financial services and financing are provided by Navistar Financial Corporation. Program eligibility, actual payments, terms and down payment are determined by Navistar Financial Corporation's credit team based upon creditworthiness of customer.

2. Navistar Financial Corporation does not provide or endorse any tax or accounting advice or tax strategy to its dealers, customers or potential customers. You should consult with your own tax and accounting advisor on all such matters relating to the loan or lease financings described in this brochure.

3. TRAC leases are limited to motor vehicles leased to businesses and must be used for commercial purposes at least 50% of the time.

\* Lessor & Lessee take pro-rata portion of the estimated residual value risk.

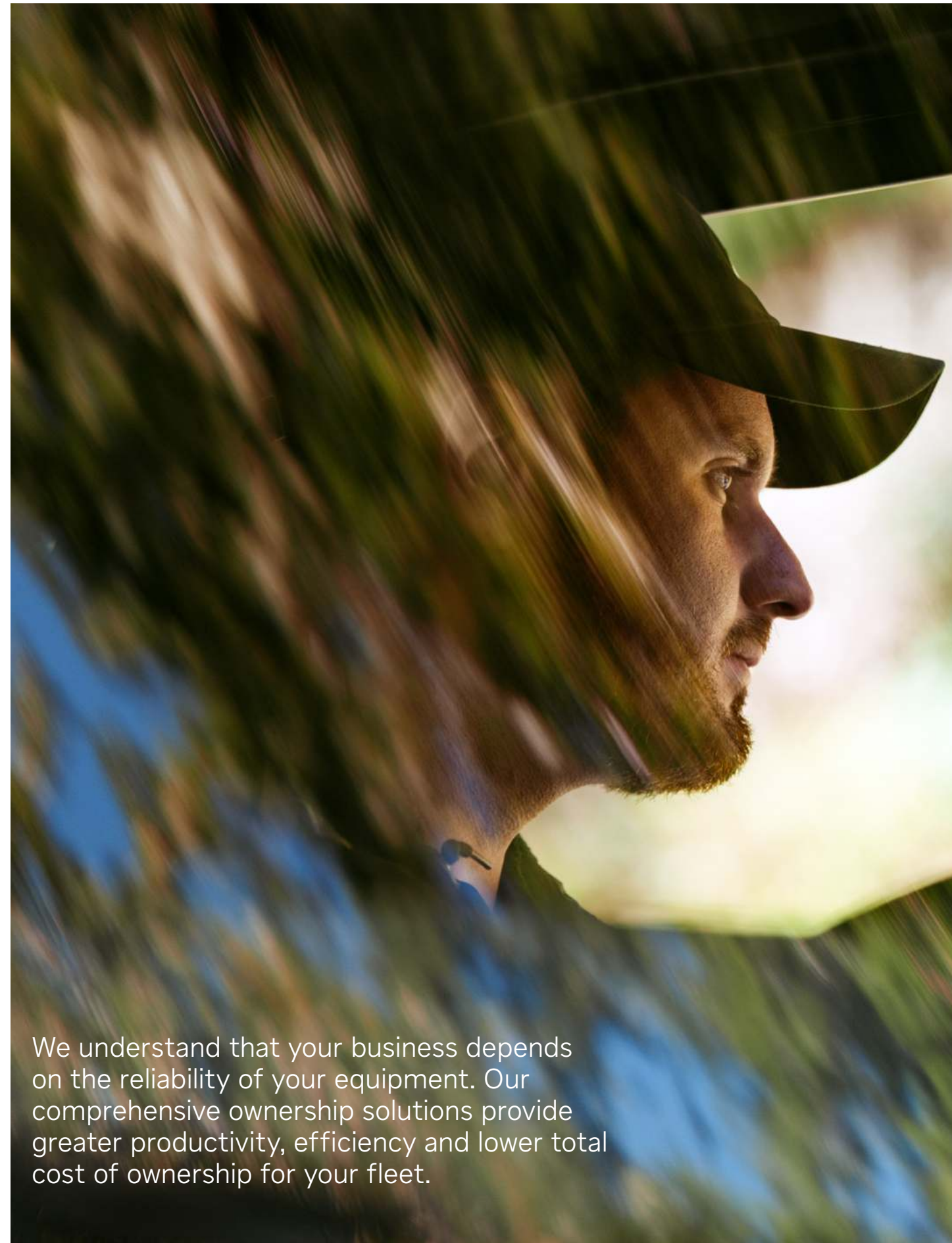

We understand that your business depends on the reliability of your equipment. Our comprehensive ownership solutions provide greater productivity, efficiency and lower total cost of ownership for your fleet.

# SERVICE CONTRACTS.

Package Options		Complete (Best Value)	Extended	Core
Maintenance and Service	Planned Maintenance Multi-point inspection Proactive Service Planning and Scheduling Customer Notifications Service Event Orchestration	✓ ✓ ✓ ✓ ✓	✓ ✓ ✓ ✓ ✓	✓ ✓ ✓ ✓ ✓
Powertrain Coverage*	Engine and Aftertreatment DEF System Transmission and Clutch	✓ ✓ ✓	✓ ✓ ✓	
Non-Powertrain Coverage*	Cooling and HVAC Starter / Alternator / Electrical Suspension and Steering Axles / Propshaft / Frame and Bumper Braking and Fuel Systems	✓ ✓ ✓ ✓ ✓		
Towing Coverage		Optional	Optional	Optional
<b>Coverage Term Options</b>				
3 Years / 300,000 Miles 4 Years / 400,000 Miles 5 Years / 500,000 Miles	Not all businesses have the same coverage requirements. Choose the package and term that suits your needs.			

### PLANNED MAINTENANCE

Consistent, high quality work performed with genuine OEM parts and lubricants that will keep your truck performing at its best. All backed by the industry's largest service network.

### PROACTIVE SERVICE PLANNING

Using remote vehicle health and performance data, our team will support you with notifications for upcoming planned maintenance and service needs. By working with you to schedule this work in advance, the service location can be prepared for arrival and get your vehicle back in service as fast as possible.

### SERVICE EVENT ORCHESTRATION

We offer resources dedicated to managing and expediting service and repair events, including reviewing repair history, ensuring calibrations are up to date, coordinating technical support when needed and providing timely communications and service product updates to keep you informed.

### COMPLETE VEHICLE COVERAGE

Protect your vehicle's powertrain and other key components, including electrical, cooling, suspension systems, and more. Plans feature a guaranteed \$0 deductible, 100% parts and labor coverage, and NO claims maximums.

### TOWING COVERAGE

Protects you and reduces out-of-pocket expenses in the event of a warrantable roadside failure.

These service contracts are available at no financing cost. Ask your dealer about a payment program through International™ Financial.



Making money means keeping your vehicles on the road.

That's why uptime is so important to us. Dependable equipment spec'd for your needs or requirements is just the beginning. We also focus on fuel economy, preventive maintenance, optimized service intervals and more to make sure the low cost of ownership of our vehicles helps keep you in the black.

**Maximum Uptime Repair Before Failure**

Prognostics move unplanned repairs to planned, optimizing maintenance using vehicle performance and predictive data.

**Predictive Parts Stocking**

Dealer parts inventory management uses AI and telematics data to predict stocking needs. This ensures the best parts are on dealer shelves to support customers.

**Parts You Need Where and When You Need Them**

Our partnership with Love's Truck Care & Speedco adds 400+ additional locations for quick, conveniently located access to light mechanical and select warranty work.\*

International  
Dealer Locations

700

Love's Truck Care  
& Speedco Locations

400



**TRUCK CARE**

Total Service  
Locations

1,100

Find out more at  
international.com

2701 Navistar Drive  
Lisle, IL 60532 USA



Note: The information and conclusions contained herein are believed to be correct at time of publication, but do not necessarily apply to similar vehicles with different specifications or with production dates after the production of this publication. Vehicles with different specifications or later dates of production may yield different results. Vehicle specifications are subject to change without notice. TAD16013 09/2024 ©2024 International Motors, LLC. All rights reserved. All marks are trademarks of their respective owners.

