

eMV™ SERIES TRUCK

PRODUCT BROCHURE



A silver International eMV Series truck is shown driving on a winding asphalt road that curves through a hilly, green landscape. The truck is a medium-duty model with a dump body. The background features rolling hills under a clear blue sky with a few wispy clouds. The overall scene conveys a sense of ruggedness and adaptability.

SMART. ADAPTABLE.

REVOLUTIONARY.

**WELCOME TO A NEW ERA
OF EFFICIENCY.**

The electric truck is here. It's making deliveries; it's hauling materials; it's keeping produce cool. And it's doing all of these jobs on the same proven foundation as the diesel International® MV™ Series truck – it just happens to be electric. Easy to use, comfortable to operate and offering iron-clad dependability, the International® eMV™ Series truck is a groundbreaking solution with real-world usability. It's the electric truck – built just right.



The International eMV Series truck offers ePower and ePTO options that use the propulsive batteries to power a wide range of body applications. From a simple plug-in to an electric motor with an SAE B flange, you'll have the muscle needed to get the job done.

FACTORY- INSTALLED BODY POWER OPTIONS.



ePTO

The factory-installed ePTO is ready to power your boom, crane, bucket and more. Quiet, electric power offers a variety of benefits, including the ability of operators in the bucket to easily communicate with those on the ground.

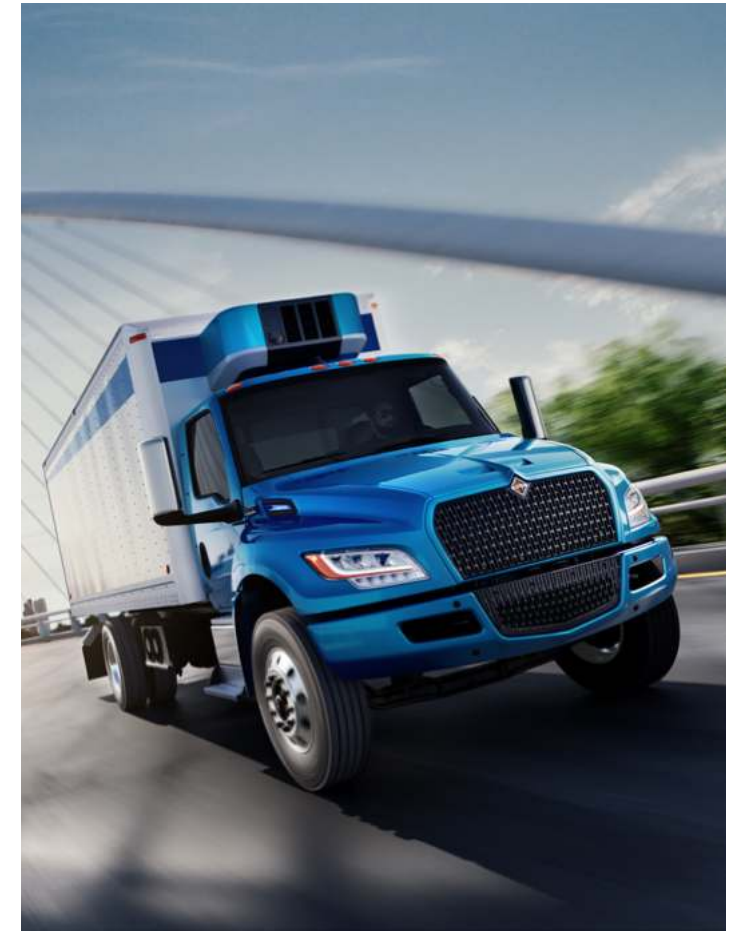

ePOWER

The power from the propulsive battery can be utilized to operate energy-intensive body applications like refrigeration. This means food and other perishables can be delivered locally in an emission-free manner.

ePTO Electrical System

Single connection

- High voltage - 210* kWh Lithium Iron Phosphate batteries with dedicated HVAC system
- 609V nominal operating voltage
- Amphenol PowerLok Gen2
- Typical applications: Utility, Dump

ePower Electrical System

Dual connection

- High voltage - 210* kWh Lithium Iron Phosphate batteries with dedicated HVAC system
- 609V nominal operating voltage
- X2 connectors @ 13.5-14.2 kW continuous power each - Fused peak power of 19.7 kW
- TE HVA280 connectors
- Typical applications: Refrigerator, Shredder

*Usable capacity is approx. 189 kWh. Actual range is based on environmental conditions, driving behaviors, etc.

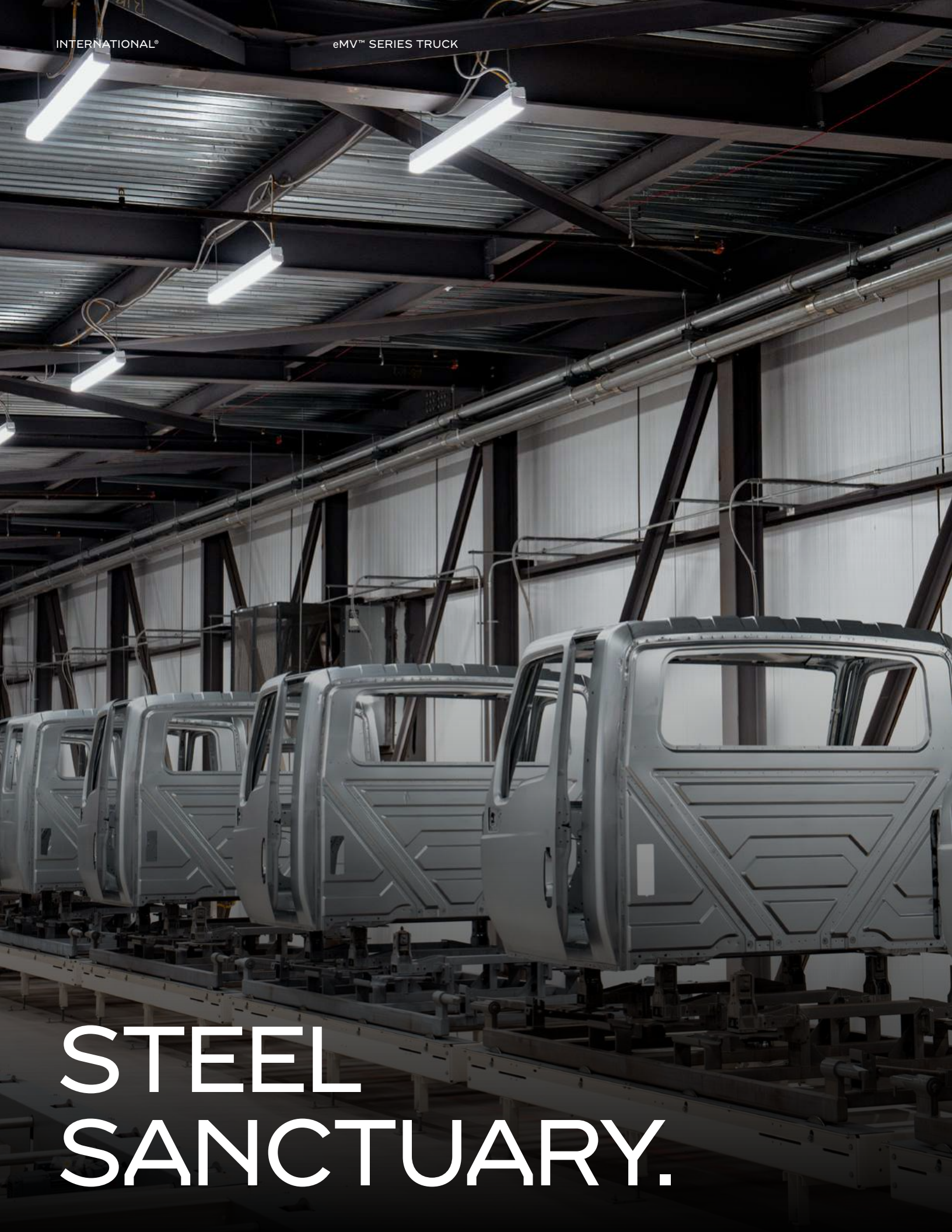

STEEL SANCTUARY.

Anti-Corrosion that's Anti-Compromise

At International®, longevity is the head of the hammer. Which is why every welded International eMV Series cab assembly is dipped into an electrostatically applied primer as part of a rigorous paint, sealing and coating process that provides superior corrosion and fade resistance – all backed by a 5-year perforation corrosion warranty.

Corrosion Protection Process

- Stamped steel with 60G/60G dual sided galvanized coating
- Custom-engineered caustic and surfactant formula cleans and preps the steel
- Proprietary tri-metal (nickel, zinc, manganese) phosphate blend provides robust corrosion protection and the first level of paint adhesion
- Epoxy-based electrodeposition primer, or e-coat is applied. This covers and seals the entire exposed metal surface of the cab
- Acrylic basecoat
- Urethane clearcoat

Top-Down Strength

All eMV Series configurations (regular, crew and extended cab) pass the rigorous SAE J2422 roof strength test.

Corrosion Protection

- | | | |
|----|---------------------------------|---|
| 01 | InterCoat® ChemGuard Coating | Think of it as a self-healing layer of skin on our galvanized steel. This inter-reactive, chrome-zinc phosphate coating is used on floor and toe kick panels to help extend integrity. The self-rejuvenating properties allow surface cuts, scratches and perforations to maintain corrosion protection |
| 02 | Optional Spray-On Liner Coating | This available polyurethane and polyurea formulation creates a protective tray on the cab floor that contains spills, as well as any of nature's elements that make their way inside. Durable and long-lasting, optional spray-on liner coating is an OEM-grade protective coating designed to guard against abrasion, corrosion and impact and can be found on over 4 million pickup bedliners |
| 03 | Reinforced B-Pillars | |

E-Coat Paint Process

- | | |
|----|------------------|
| 04 | Clearcoat |
| 05 | Base Coat |
| 06 | E-coat |
| 07 | Galvanized Steel |



01

02

03

04

05

06

07

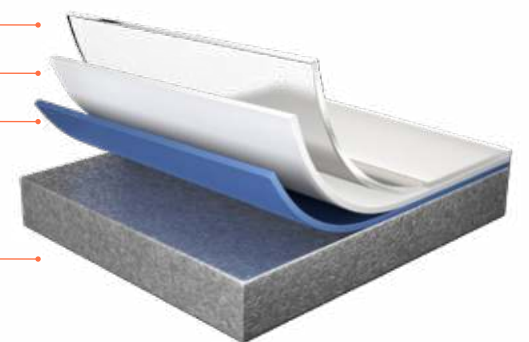

A FAMILIAR ENVIRONMENT. NO LEARNING CURVE REQUIRED.

Comfort. Visibility. Safety. It's everything you know and love about the International MV Series interior, which means you'll be right at home with the International eMV Series from the get-go. Inside you will find a powerful HVAC system, controls and switches that are easy to find, reach and operate — even when wearing gloves. A sloped hood provides enhanced visibility and door-mounted mirrors are expertly positioned for maximum rearward visibility. Even the air horn lanyard is placed exactly where drivers told us it should be.



Every detail inside the International eMV Series cab has been researched, designed and extensively tested by the real experts – drivers and body companies. The final result is a true collaboration of those who know what it takes to be productive and successful.

Smart Productivity

- | | |
|----|---|
| 01 | The steering wheel adds more functions at the driver's fingertips with integrated back lit, laser-etched labeling for improved durability and visibility. Plus, all the controls within the cab are designed to be operated easily while wearing gloves |
| 02 | A standard flat instrument panel includes a center-mounted vent to keep the middle passenger comfortable while providing space for extra legroom or a large floor-mounted body control module |
| 03 | Switch panel comes standard with 3-level regenerative braking, off-road traction control, suspension dump and lift gate. <ul style="list-style-type: none"> • Large, easy-to-read backlit text • Warning lights can be any of seven colors • Blank "windows" available for custom labeling by the customer |

Cab Features

	Classic	Diamond
Cab Trim Panels	Easy-To-Clean Plastic	Easy-To-Clean Plastic
Door Trim	Single Piece Door Panel With Integrated Door Pocket	Single Piece Door Panel With Integrated Door Pocket
Trim Inserts	Neutral	Mineral Teak
Instrument Panel	Black	Black
Gauge Cluster	New Digital Full Color Cluster	New Digital Full Color Cluster
Accent Color	Neutral	Dark Neutral
Sun Visors	Two	Three
Lighting	LED	LED
Window Controls	Power	Power
Lock Controls	Manual or Power	Power
Cup/Bottle Holders	Four	Four
Overhead Console	Molded Plastic with Retainer Nets and CB Radio Housing	Molded Plastic with Retainer Nets and CB Radio Housing
USB Accessory Port	Up to 5 Available	Up to 5 Available

SITUATIONAL AWARENESS. ELEVATED.

Uptime is much more than simply being able to work. It also requires giving drivers the tools they need to be seriously productive. It's why the International eMV Series instrument cluster has all the information drivers need, presented in a familiar and intuitive layout.

01	Power vs Regen indicates how much power is being used by the motor when accelerating or how much power is being returned to the batteries during regenerative braking
02	Primary air system gauge
03	Vehicle ready indicator
04	Secondary air system gauge
05	Propulsion load %
06	Range estimate
07	Battery temp indicator
08	Drive motor temperature indicator
09	Regenerative braking indicator, levels 1, 2, 3
10	12-volt battery gauge

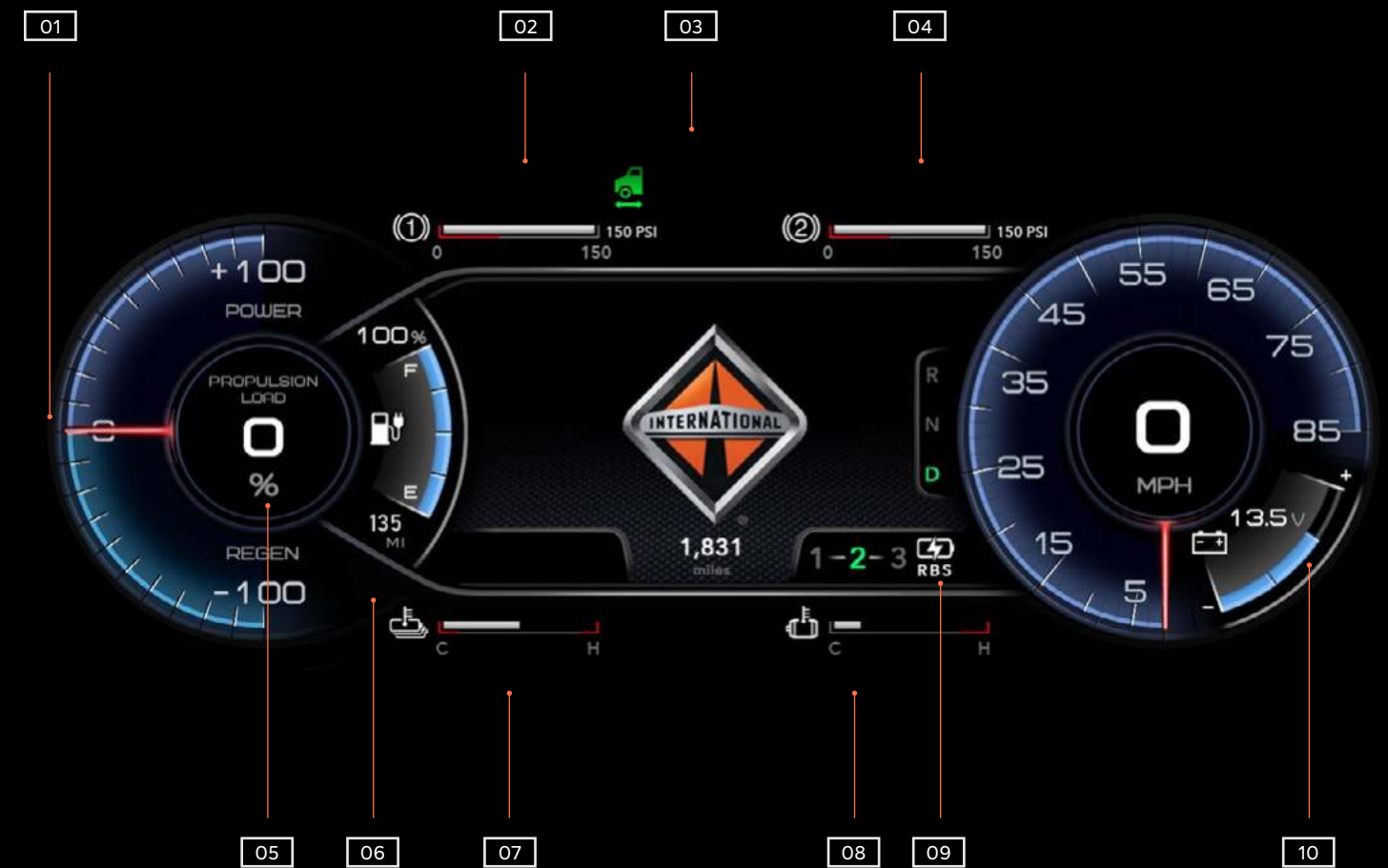



GETTING YOU READY TO
MAKE THE SWITCH.

OUR DEALERS AND TRUSTED ADVISORS ARE ALWAYS AVAILABLE TO HELP YOU MOVE FORWARD WITH ELECTRIFICATION.

ALL IT TAKES ARE THREE EASY STEPS:

**STEP 1
CONSULTING**

Our discovery workshops dive into your fleet's electrification needs and concerns, building a customized EV roadmap for success.

**STEP 2
CHARGING**

We assess the placement of hardware and infrastructure, finding the best ways to support your vehicle charging and uptime.

**STEP 3
CUSTOMER ONBOARDING**

We ensure your charging locations, staff and remote diagnostics are prepared for your electric vehicle to hit the road.

The International trusted advisors will set up your EV roadmap by identifying your short-term and long-term goals, understand your current electric plan and what upgrades may need to be completed. The team will provide end-to-end support and be your single point of contact throughout the entire process.

STEP 1: CONSULTING.

Strategy and Scalability

- Route simulations
- Conduct TCO calculations to understand the costs (and cost savings) involved with deploying EVs
- Assistance with federal and state rebates, grants, funding incentives and tax incentives
- Determine how and when to electrify your fleet

Site Selection and Assessment

- Identify and prioritize target sites
- Perform due diligence on sites
- Review zoning, power capacity, space; analyze existing power sources

Infrastructure Concept Development

- Determine the type and level of EV charging equipment
- Determine vehicles per location; verify charger output requirements; calculate future fleet growth

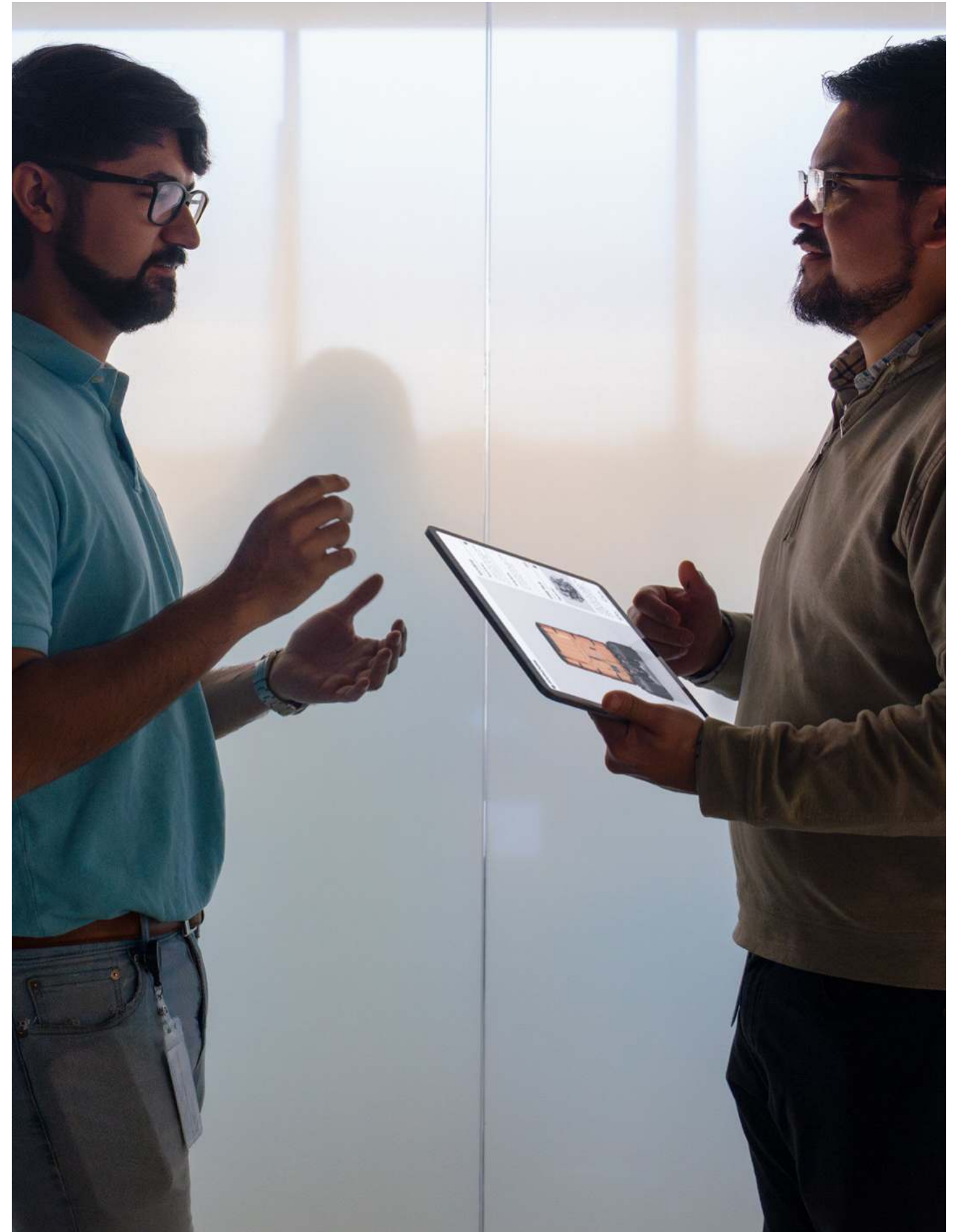

Building out a charging solution that's appropriate for today but flexible enough to grow as you grow can be a complicated process. We're here to make that process as smooth as possible by working side by side through site planning and engineering, AC and DC charger installation, site management, equipment certification and financing for both vehicles and infrastructure.

STEP 2: CHARGING.

LEVEL 2 AC 80 amps

This AC Level 2 Charger Solution can be used for fleet operations that have longer charge times and is also recommended for diagnostic activities or overnight charging. It is very compact and can be installed in most fleet garages or bays.

SPECIFICATIONS

- Max Power Output: 19.2 kW
- Max Current Output: 80A @ 240Vac
- Cable Options: SAE J1772 Connector
- Facility Power Requirements (Volts): 208 / 240V Single Phase
- Facility Power Requirements (Amps)*: 100

KEY BENEFITS & FEATURES

- Estimated Charge Time: 189 kWh usable battery capacity - 12 hours**
- Case enclosure rated for outdoor use
- Compact and easy to install

ICE 30 KW DC FAST CHARGER

The 30 kW is a compact DCFC capable of charging with one or two connectors. This DC Wallbox is designed for easy wall-mounting or can be attached to a pedestal. This 30 kW charger is easy to operate with an intuitive touchscreen display and is ideal for fleet charging, as well as a variety of parking applications where shorter charge times are necessary.

- Max Power Output: 30 kW
- Output Voltage Range: 150 to 1000Vdc
- Cable Options: CCS1 Connector - Option of 16 ft or 25 ft cables (recommended)
- Facility Power Requirements (Volts): 480V 3-Phase Facility Power Requirements (Amps)*: 50

- Estimated Charge Time: 189 kWh usable battery capacity - 6 hours**
- User-friendly control interface allows for access management via PIN or RFID accessibility
- OCPP 1.6 standard supports interoperability across back-end platforms
- LTE modem and LAN
- TUV certification to UL 2202 to ensure safety
- 480V 3-phase input for high-efficiency conversion
- DIN 70212 and ISO 15118-2 protocol supported
- Hot galvanized steel, plastic facade and tempered glass screen construction ensures longevity

* Per charger

**20% to 100% state of charge, room temperature current production CATL LFP batteries

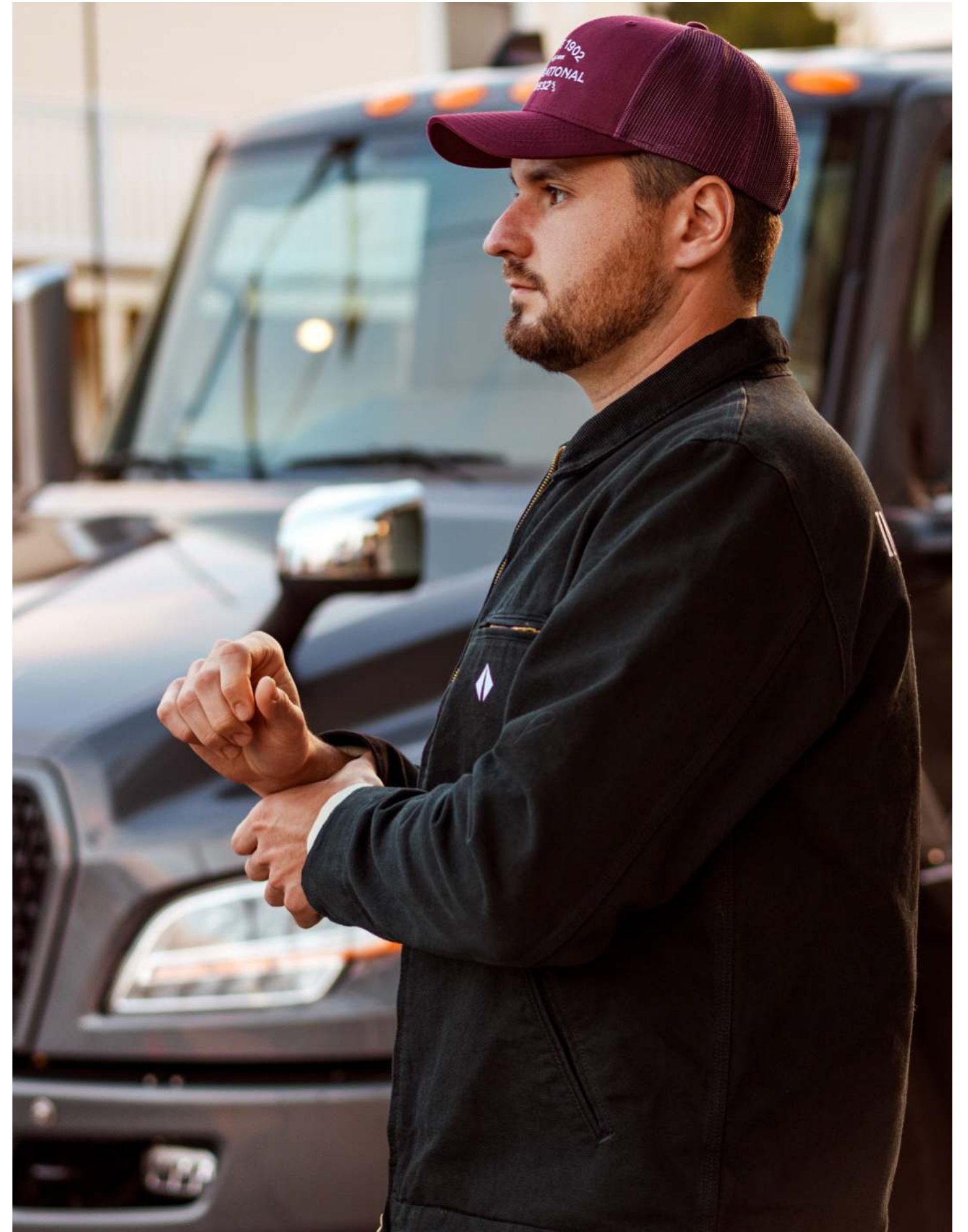

International has a dedicated team to ensure that your site is ready the moment your International eMV Series arrives. This Deployment Team works closely with all parties, including your dealer, to ensure that your infrastructure is commissioned, the vehicle arrives on time and your staff is trained and ready to begin using your electric vehicle immediately.

STEP 3: CUSTOMER ONBOARDING.

Delivery

- Confirm operability per specs
- Verify install and commissioning of equipment
- Set up remote monitoring & scheduled charging
- Deliver charge management strategy for future growth

Training

- Provide training on equipment usage and safety requirements
- Confirm vehicle readiness and provide training on advance remoted diagnostics
- Establish routine maintenance schedule
- Vehicle operation, driver training, charging operation, technician training (maintenance and inspection), storage best practices, towing, first responder training, OnCommand® Connection and any applicable charging software

Connected Vehicle

- Confirm connectivity for ongoing maintenance and monitoring

Post Deployment Process

- Reports that compare assumptions of performance and driving efficiency to actual data
- Guidance to improve efficiency and range
- Available to answer any questions about the vehicle or charging infrastructure

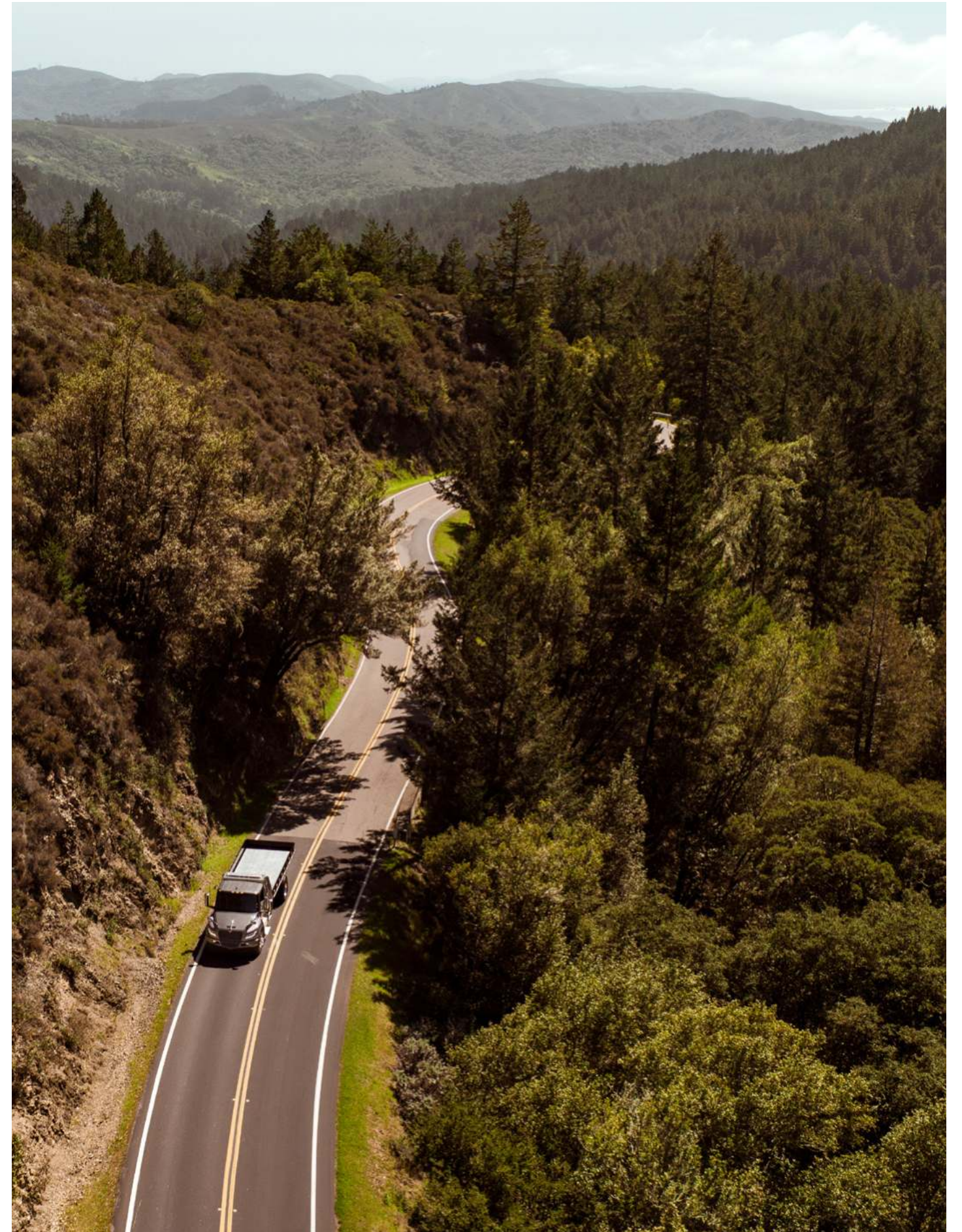

STAY THE COURSE.

Standard LED headlights offer unparalleled nighttime visibility for improved safety whether you're inside the cab or out. Adding heat for snowy, frozen environments can help to defrost quickly.

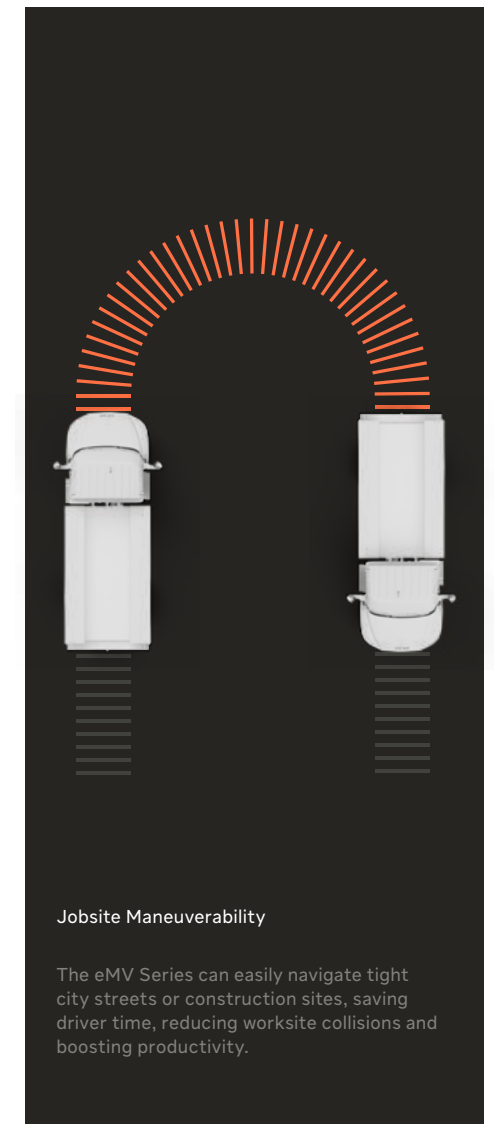
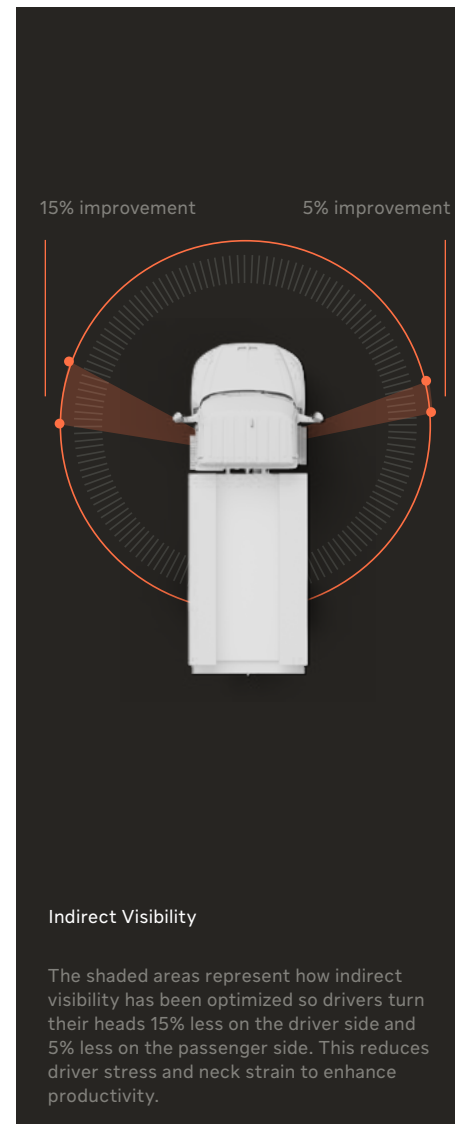
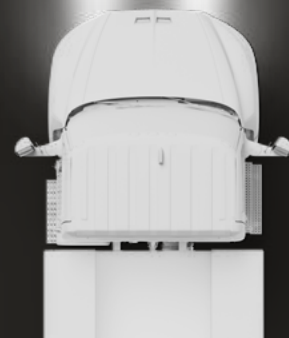

Not every trip goes as planned – and not every other driver on the road is paying attention. That's why the International eMV Series is equipped with safety systems designed to help keep your drivers (and your equipment) out of harm's way.

Anti-Lock Braking Systems (ABS)

Anti-Lock Braking Systems (ABS) help prevent the wheels from locking up during hard braking events. The system works by rapidly activating the brakes so the driver can still steer and maintain control of the truck while slowing down. This helps the driver avoid skidding, especially in slippery conditions like rain or snow. Most eMV Series non-emergency braking is accomplished through regenerative braking. This process uses the motor to slow the vehicle and directs the recaptured energy to the main battery, which helps to extend the overall range of the truck.

Electronic Stability Control (ESC)

Bendix® Electronic Stability Control (ESC) technology is a full stability system, offering both roll and yaw stability to potentially help mitigate loss of control and/or rollover. This ABS-based system can potentially recognize and assist in both understeer and oversteer loss-of-control driving events. This advanced feature is particularly helpful in adverse weather conditions, including snow, ice, rain, dust, sand and more.

Automatic Traction Control (ATC)

Automatic Traction Control (ATC) can regulate wheel spin during acceleration to help improve traction in various conditions. The ATC system will intervene automatically at lower speeds by applying braking pressure to a spinning wheel and transferring engine power to other drive wheels that have better traction. This feature is especially useful at jobsites where road conditions may include dirt, gravel, sand or ice.

eMV SERIES SPECIFICATIONS



ePower Electrical System

- High voltage - 210* kWh Lithium Iron Phosphate batteries with dedicated BTMS (Battery Thermal Management System)
- 609V nominal operating voltage
- X2 connectors @ 13.5-14.2 kW continuous power each
- - Fused peak power of 19.7 kW
- TE HVA280 Connectors
- Typical applications: Refrigerator, Shredder

ePTO Electrical System

- High voltage - 210* kWh Lithium Iron Phosphate batteries with dedicated BTMS (Battery Thermal Management System)
- 609V nominal operating voltage
- Amphenol PowerLok Gen2
- Typical applications: Utility, Dump

ePTO Mechanical System

- 40 kW** Minimum Continuous Power Operation
- 60 kW Maximum Peak Power Operation

eMV Key Features

Electrified powertrain - fully integrated ensuring all components are optimized to work with each other as a system

210* kWh Lithium Iron Phosphate (LFP) batteries - fully enclosed inside frame rails

Best-in-class regenerative braking on/off with three levels: 30%, 60% and 100% - maximizes driver control

- Improved vehicle efficiency
- Increases vehicle range
- "One" pedal style driving capability, except for a complete stop

State-of-the-art driver display

- Propulsion & regenerative load
- State of charge indicator
- Regenerative braking indicator

Charging

- SAE J1772 CCS1 AC/DC charging standard - ensures charging compatibility with most public chargers
- Up to 125 kWh capable with a DC charger
- OCC standard for 5 years with enhanced eMobility features

eMV Specifications

GVWR	25,999 and 33,000 lbs.
Model/BBC/BA	MV60E 107.9" BBC, 40" BA
Cab Configurations	Day Cab
Wheelbase Options	217", 236", 254" & 272"
Axle Configurations	4x2
Rear Axle	Single Rear Axle (4x2) Dana Spicer 23,000 lb.
Front Axle	Dana Spicer I-Beam 12,000 lb.
Frames	Heat-Treated Alloy Steel 120,000 PSI
Front Suspension	Spring, Parabolic Taper Leaf: 12,000 lbs.
Rear Suspension	21,000 lb single axle with shocks IROS Air Suspension
Frames	Heat Treated Alloy Steel 120,000 PSI
Electrical System	High Voltage - 210* kWh Lithium Iron Phosphate batteries with dedicated BTMS (Battery Thermal Management System) 609V nominal operating voltage
Brakes	Air Brakes with ABS, 4 channel Electronic Stability Program with Traction Control
Steering	TRW/Ross Power
Motor	Direct Drive Electric Motor Peak Motor Torque: 1737 lb-ft Continuous Motor Torque: 730 lb-ft
Tires	Continental
RAR (Rear Axle Ratio)	6.83

*Useable capacity is approx. 189 kWh. Actual range is based on environmental conditions, driving behaviors, etc.

**Assumes 3,000 rpm hydraulic system limit

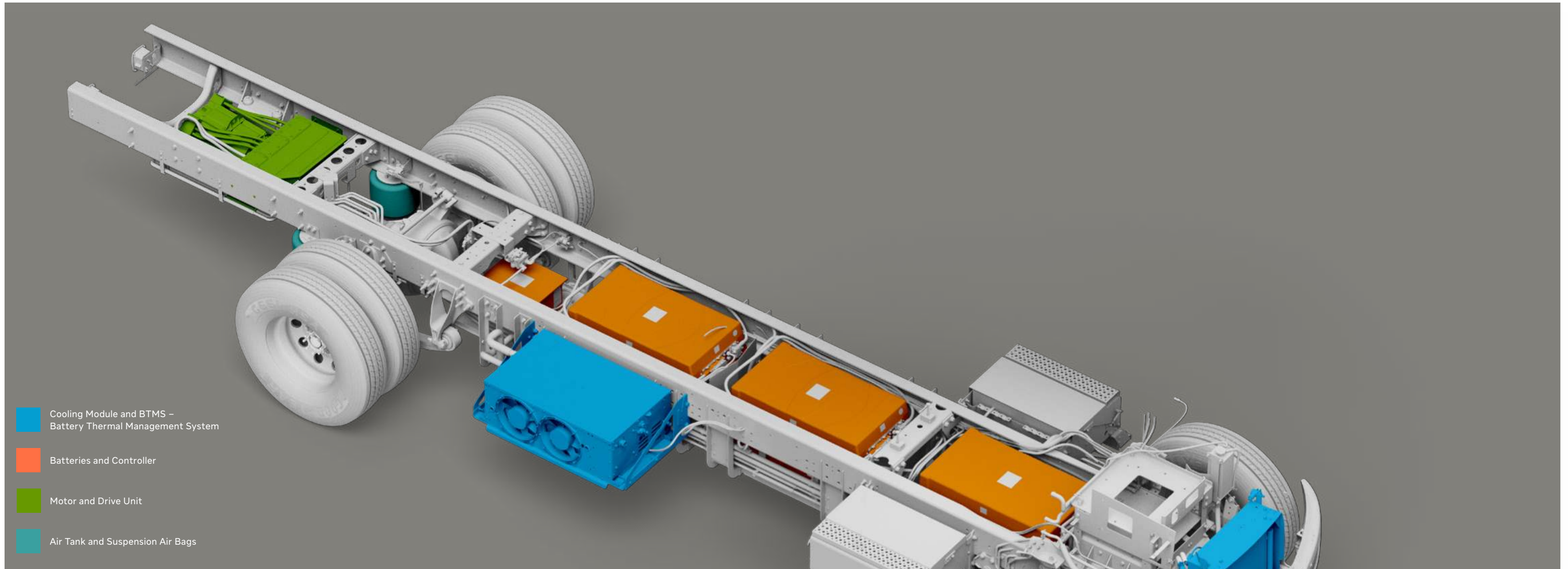

It's no secret electric vehicles require less maintenance. With substantially fewer parts, an electric motor simply does not have the maintenance or service requirements of an internal combustion engine. Plus, thanks to regenerative braking, the standard brakes last much longer between service intervals.

MAINTENANCE SCHEDULE.

Take These Off Your Service Plate

- No engine oil maintenance
- No transmission maintenance
- No fuel filters
- No turbos, no EGR, no injectors
- No engine air filters, no MAF and no O2 sensor
- No aftertreatment

Vehicle Coverage	Years	Miles
Chassis Warranty	24 months	Unlimited
Drive Battery	36 months*	150,000*
Drive Motor	36 months*	150,000*
Drive Charger & Cables	36 months*	150,000*

*GDT=350,000 hours
Gross Discharge Throughput, reflected in kilowatt-hours (kWh): Total energy discharged from the battery.

LISLE, ILLINOIS
USA
International
FROM THE FIELD
TO THE FAST LANE
EST. 1902

SERVICE SOLUTIONS.

- Advanced Remote Diagnostics
- Service Communications
- International™ Financial
- Service Contracts

International is the first and only OEM to create connected solutions built for how you do business - designed on an open architecture, integrated with over 30 third party telematics providers, and compatible with all makes and models.*

INDUSTRY-LEADING CONNECTIVITY.

Take your performance to the next level. Our connected vehicle technology includes tools designed to give your business and operations that extra edge.

5 Years On Us

Factory installed telematics and five years of connected vehicle services are standard on new eMV Series trucks.

Advanced Preventive Maintenance

Optimize PM spending with data-driven, customized interval recommendations for your trucks.

Gateway Integrations

Seamless access to major fleet management and compliance software providers, without the cost and complexity of additional telematics hardware on your vehicle

EV Health Reporting

See real-time charging activity, state of charge, estimated range, and more.

* For most commercial vehicles powered by diesel engines, 2007 MY and later.

Our Advanced Remote Diagnostics platform features:

- Reports on vehicle health issues that include severity ratings, likely needed parts and service, and recommended actions.
- Comprehensive vehicle health reports that include performance data, fault history and more.
- Up-to-date GPS location with customizable geofencing reports that can help ensure vehicles are where they need to be.
- Insights delivered how you need it — via our online portal, your email inbox, a mobile app and more.

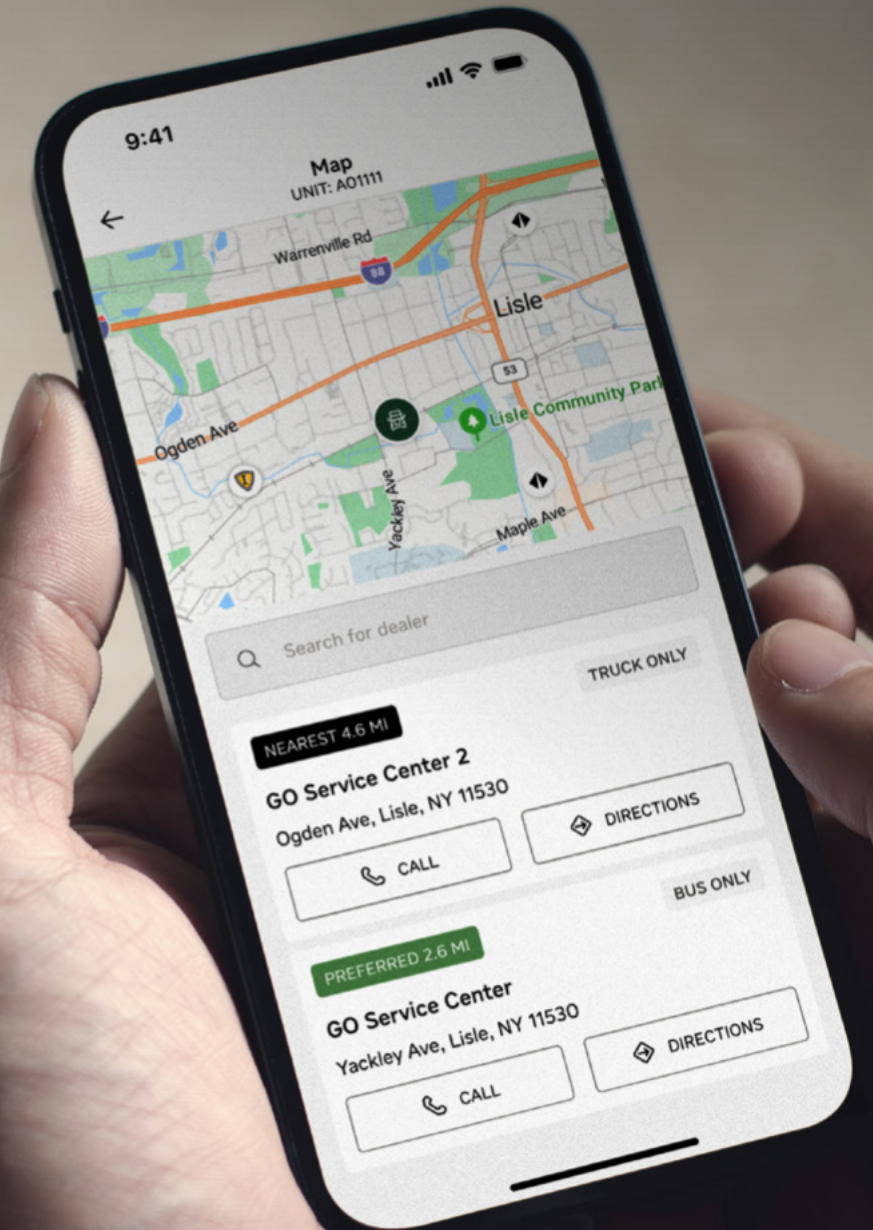

Our industry-leading service communications tool is designed to accelerate the repair process, streamline communications with your dealer service center and drive greater uptime.

SERVICE COMMUNICATIONS WITH YOUR DEALER.

FEATURES INCLUDE:

- Seamless communications with dealers, including service request initiation, up-to-date repair status, and estimate approvals
- Complete VIN-based information: asset specs, complete parts catalog, remote health data, and more
- Complete service history, up-to-date campaign information, and engine calibration status. Integration with parts inventory systems shows which dealer locations have the parts you need on the shelf now

5 YEARS ON US

- Service Communications is included for five years standard on new eMV Series trucks.

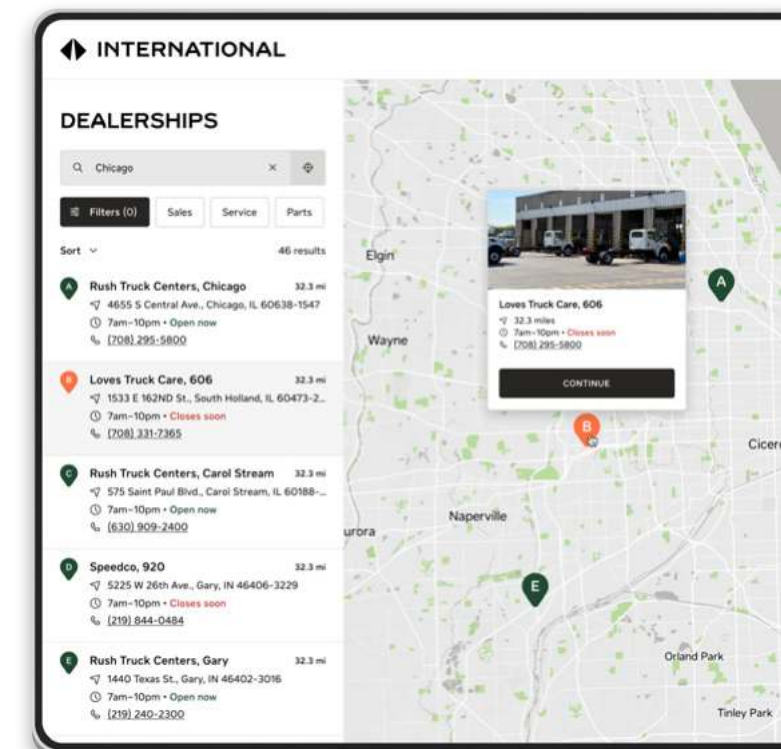

UNLOCK YOUR POTENTIAL.

International™ Financial can help you take your business to the next level. We offer financing solutions for new and used International® trucks and IC Bus® school buses, as well as used vehicles of all makes and models offered through International Truck dealers, IC Bus dealers and International Used Truck Centers.

As an expert in the commercial vehicle industry, we have a deep understanding of your wants and needs and are ready to help enable your success.

We offer flexible solutions to fit your truck, bus, vehicle or equipment financing needs, helping you secure the best financing products for your specific situation. Whether you're looking for a fleet vehicle loan or you need to lease fleet vehicles, our financial team can provide you with the best option suited to your business.

THE CHOICE IS YOURS.

The transition to an electric fleet may seem daunting considering the potential cost and infrastructure, but rest assured, International Financial can provide the financing you need for both vehicles and chargers. As an expert in the commercial vehicle industry, we have a deep understanding of what it takes to make the switch and are ready to help enable your success.

Compare Equipment Finance Options

	Loan	Finance Lease	TRAC Lease	Split TRAC Lease	FMV Lease
ICE Vehicles	✓	✓	✓	✓	✓
Electric Vehicles	✓	✓	✓	✓	✓
Permanent Chargers	✓	✓	✓		
Mobile Chargers	✓				

Electric Vehicle Financing Term Lengths

Minimum Term	Vehicle and chargers: 12 months
Maximum Term	Electric CE Series: 96 months eMV Series: 84 months
Chargers	Coterminous with Vehicle

Other products and services

Content Available for Financing	ICE	EV
Vehicle	✓	✓
Vehicle Extended Service Contract	✓	✓
Vehicle Connectivity	✓	✓
Vehicle Towing (breakdown)	✓	✓
Vehicle Comprehensive Ownership Solution	✓*	✓**
Charger		✓
Charger Extended Service Contract		✓
Charger Connectivity		✓

1. International™ Financial services and financing are provided by Navistar Financial Corporation. Program eligibility, actual payments, terms and down payment are determined by Navistar Financial Corporation's credit team based upon creditworthiness of customer.
2. Navistar Financial Corporation does not provide or endorse any tax or accounting advice or tax strategy to its dealers, customers or potential customers. You should consult with your own tax and accounting advisor on all such matters relating to the loan or lease financings described in this brochure.

3. TRAC leases are limited to motor vehicles leased to businesses and must be used for commercial purposes at least 50% of the time.

* Lessor & Lessee take pro-rata portion of the estimated residual value risk.

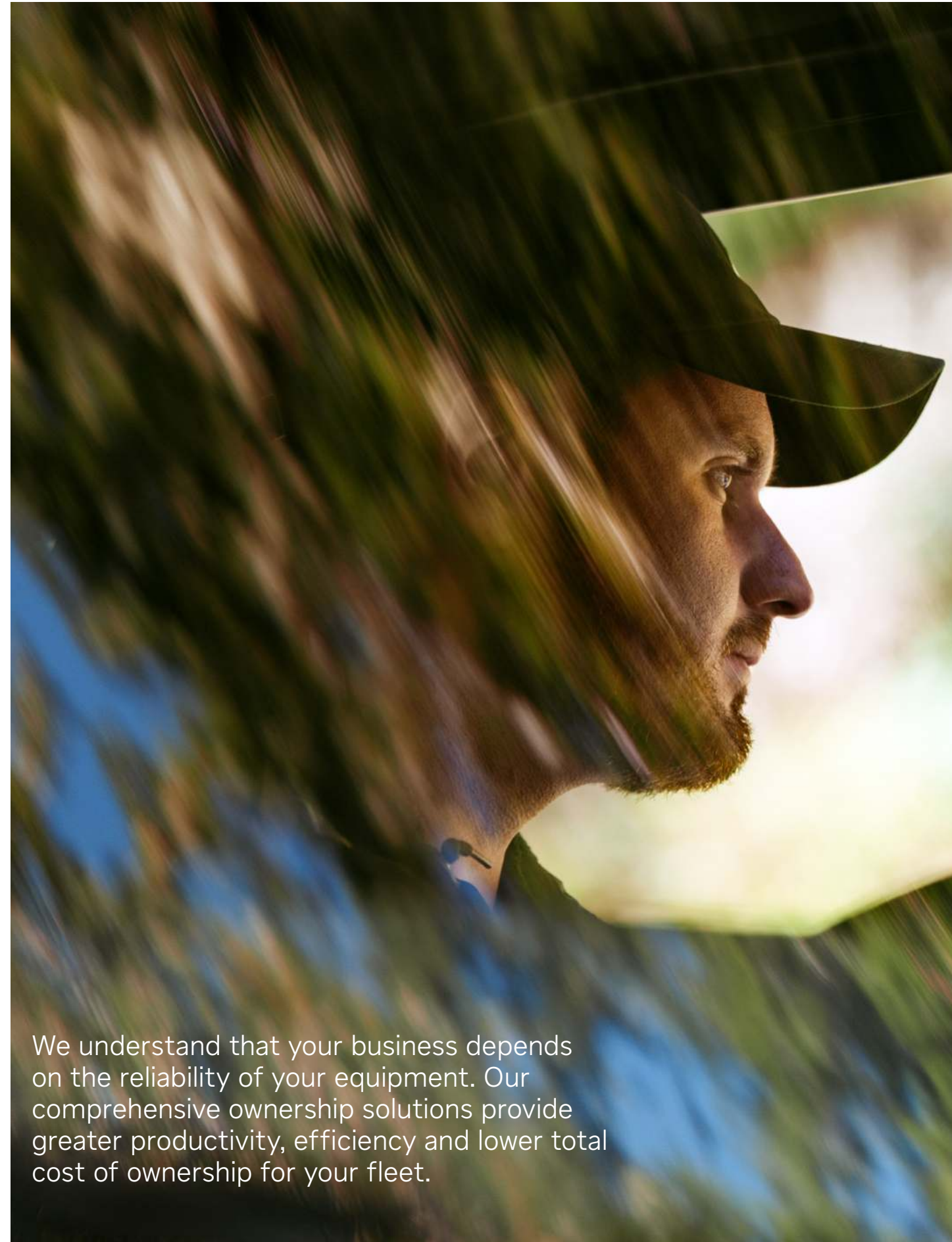

We understand that your business depends on the reliability of your equipment. Our comprehensive ownership solutions provide greater productivity, efficiency and lower total cost of ownership for your fleet.

SERVICE CONTRACTS.

PLANNED MAINTENANCE

Consistent, high quality work performed with genuine OEM parts and lubricants that will keep your truck performing at its best. All backed by the industry's largest service network.

PROACTIVE SERVICE PLANNING

Using remote vehicle health and performance data, our team will support you with notifications for upcoming planned maintenance and service needs. By working with you to schedule this work in advance, the service location can be prepared for arrival and get your vehicle back in service as fast as possible.

SERVICE EVENT ORCHESTRATION

We offer resources dedicated to managing and expediting service and repair events, including reviewing repair history, ensuring calibrations are up to date, coordinating technical support when needed and providing timely communications and service product updates to keep you informed.

COMPLETE VEHICLE COVERAGE

Protect your vehicle's powertrain and other key components, including electrical, cooling, suspension systems, and more. Plans feature a guaranteed \$0 deductible, 100% parts and labor coverage, and NO claims maximums.

TOWING COVERAGE

Protects you and reduces out-of-pocket expenses in the event of a warrantable roadside failure.

These service contracts are available at no financing cost. Ask your dealer about a payment program through International™ Financial.



We understand making money means keeping your vehicles on the road.

That's why uptime is so important to us. Dependable equipment spec'd for your needs or requirements is just the beginning. We also focus on preventive maintenance, optimized service intervals and more to make sure the low cost of ownership of our vehicles helps keep you in the black.

Maximum Uptime Repair Before Failure

Prognostics move unplanned repairs to planned, optimizing maintenance using vehicle performance and predictive data.

Predictive Parts Stocking

Dealer parts inventory management uses AI and telematics data to predict stocking needs. This ensures the best parts are on dealer shelves to support customers.

Parts You Need Where and When You Need Them

Our partnership with Love's Truck Care & Speedco adds 400+ additional locations for quick, conveniently located access to light mechanical and select warranty work.*

International Dealer Locations

700

Love's Truck Care & Speedco Locations

400

Total Service Locations

1,100



Find out more at
international.com

2701 Navistar Drive
Lisle, IL 60532 USA



Note: The information and conclusions contained herein are believed to be correct at time of publication, but do not necessarily apply to similar vehicles with different specifications or with production dates after the production of this publication. Vehicles with different specifications or later dates of production may yield different results. Vehicle specifications are subject to change without notice. TAD21007 09/2024 ©2024 International Motors, LLC. All rights reserved. All marks are trademarks of their respective owners.

