

MV™ SERIES

PRODUCT BROCHURE



BIG TIME UPTIME. ALL DAY. EVERY DAY.

THE INTERNATIONAL® MV™ SERIES TRUCK

The International® MV™ Series truck is purpose-built to be out on the highway, at the jobsite, first on the scene and anywhere else work needs to get done. Its durable, spacious cab is crafted for optimal comfort and control. Its proven Cummins® engines are tuned to maximize torque, dependability and efficiency. The breakaway mirrors limit potential damage and the sloped hood helps enhance visibility and safety. The industry-leading intelligence of its Diamond Logic® electrical system is seamlessly integrated to help protect both your crew and your equipment.

The MV Series: More uptime. More capability. More of what you need. Built just right.





TRUCKS BUILT JUST RIGHT FOR YOUR EVERY NEED.

From torque, payload and application options to our highly advanced and versatile Diamond Logic electrical system, International MV Series trucks expand the ability to get big things done. When someone's stranded or something is broken, needs to be hooked up, cut down or cleaned out, these trucks churn with productivity. Choose from two proven Cummins® engines, three cab sizes and a 4x2 or 6x4 axle configuration. Then select the exact specifications to suit your job. The MV Series can conform to your needs.

STEEL SANCTUARY.

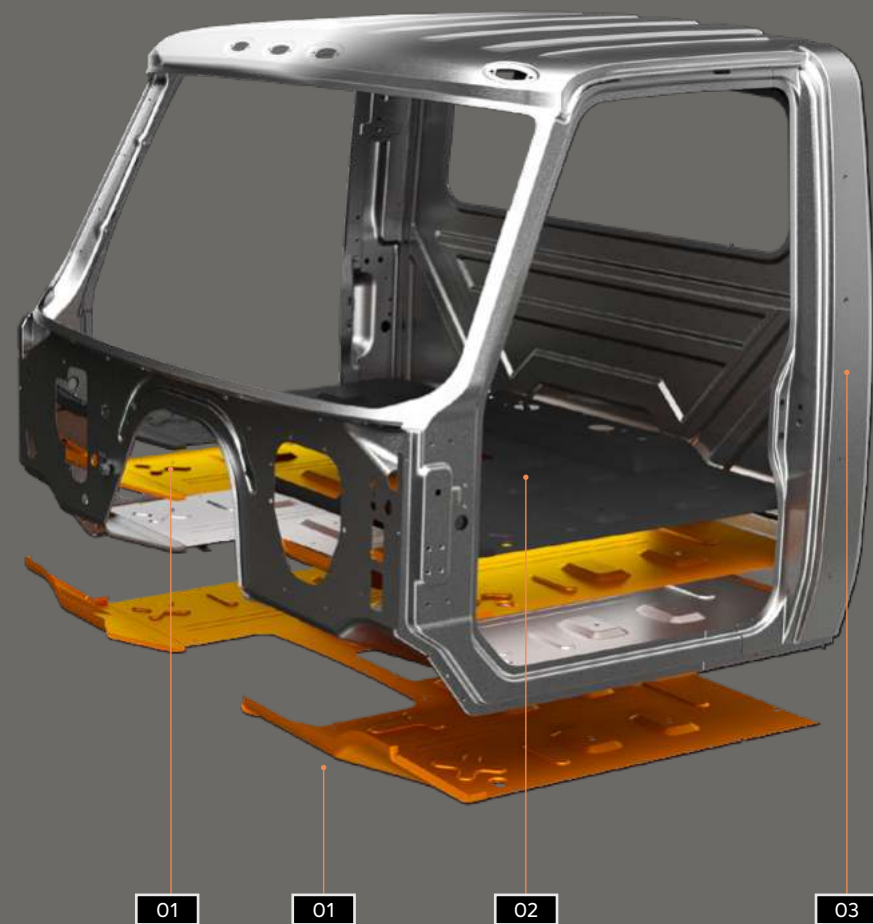

PARTS AND SPECIFICATIONS

01	InterCoat® ChemGuard Coating
02	Optional Spray-On Liner Coating
03	Reinforced B-Pillars

For Strength, Safety and Comfort

The International MV Series cab wraps your crew in a high-strength, low-alloy (HSLA) reinforced, cold-rolled steel construction that combines the corrosion resistance of aluminum with the world-class fit, finish and strength of steel. The result is a larger, quieter, more protective interior with air- and water-tight seals.

InterCoat® ChemGuard

Think of it as a self-healing layer of skin on our galvanized steel. This inter-reactive, chrome-zinc phosphate coating is used on floor and toe kick panels to help extend integrity. The self-rejuvenating properties allow surface cuts, scratches and perforations to maintain corrosion protection.

Optional Spray-On Coating Floor Protection

This available polyurethane and polyurea formulation creates a protective tray on the cab floor that contains spills as well as any of nature's elements that make their way inside. Durable and long-lasting, the spray-on liner coating is an OEM-grade protective coating designed to guard against abrasion, corrosion and impact and can be found on over 4 million pickup bedliners.

MV Series Features

- A high-strength, low-alloy (HSLA) reinforced, cold-rolled steel cab delivers superior corrosion resistance as well as world-class fit and finish
- The welded cab assembly is dipped into an electrostatically applied primer as part of a paint process that provides outstanding resistance to corrosion and fading.

Top-Down Strength

All MV™ Series configurations (regular, crew and extended cab) pass the rigorous SAE J2422 roof strength test.

Anti-Corrosion That's Anti-Compromise

At International, longevity is the head of the hammer. Which is why every welded MV Series cab assembly is dipped into an electrostatically applied primer as part of a rigorous paint, sealing and coating process that provides superior corrosion and fade resistance – all backed by a 5-year perforation corrosion warranty.

Corrosion Protection Process

- Stamped steel with 60G/60G dual sided galvanized coating - standard on dash and toe and floor panels
- Custom-engineered caustic and surfactant formula cleans and preps the steel
- Proprietary tri-metal (nickel, zinc, manganese) phosphate blend provides robust corrosion protection and the first level of paint adhesion
- Epoxy-based electrodeposition primer, or e-coat is applied. This covers and seals the entire exposed metal surface of the cab
- Acrylic basecoat
- Urethane clearcoat

E-Coat Paint Process

01	Clearcoat
02	Base Coat
03	E-coat
04	Galvanized Steel

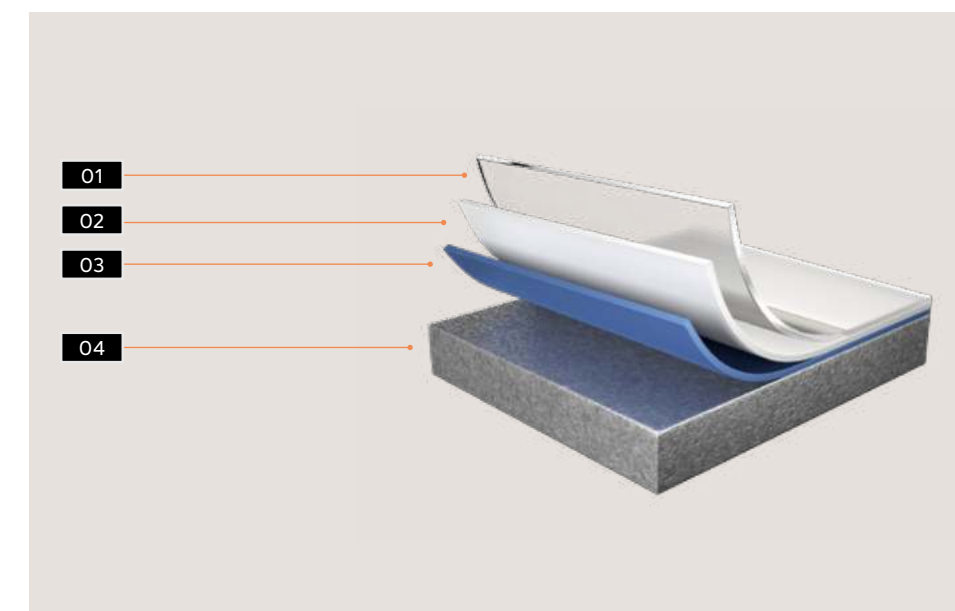

DRIVERFIRST™

Welcome to the ultimate seat of power. Inside the MV Series is a command center designed around the driver. Comfort. Visibility. Safety. Room for a third front passenger without knocking their knees. Plus, the optional stalk shifter on the Allison 1,000 & 2,000 (required on 3000) allows for shifting and application of the optional Jacobs brake without taking your eyes off the road, and allows more room for a third front passenger. It comes from talking to real drivers. Listening to their needs. And designing a truck around their priorities – a philosophy we call DriverFirst.

This driver-centric approach starts with a cavernous cab and meticulous attention to every detail. There's a powerful HVAC system to keep you comfortable while on the job. Controls and switches are easy to find, reach and operate, even when wearing gloves. A redesigned hood enhances visibility. Door-mounted mirrors are positioned to see more while turning your head less to reduce fatigue. Even the air horn lanyard is placed exactly where drivers told us it should be.



THINK OF IT AS A 200+ HP
CORNER OFFICE.

POWERFUL PRODUCTIVITY.

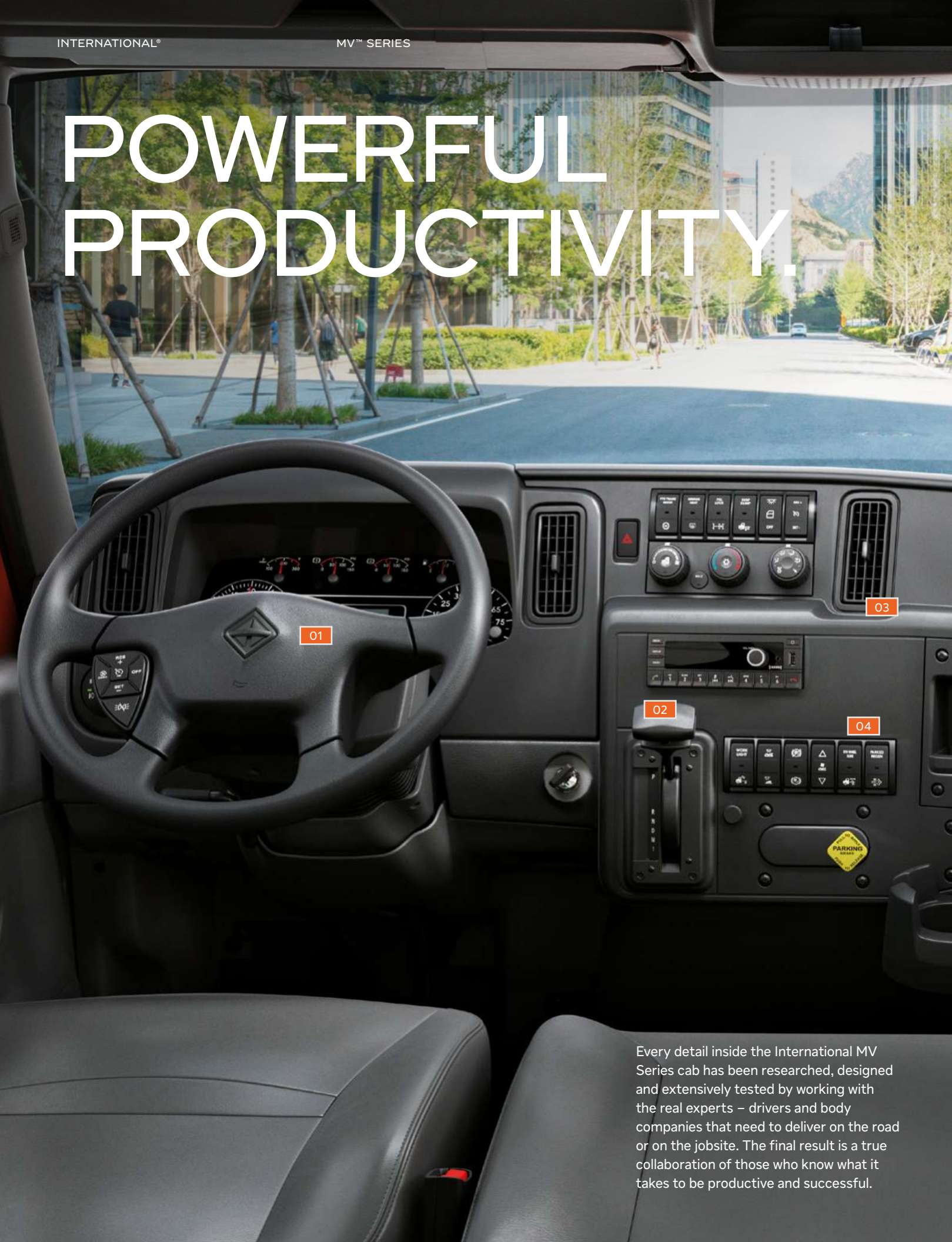

Every detail inside the International MV Series cab has been researched, designed and extensively tested by working with the real experts – drivers and body companies that need to deliver on the road or on the jobsite. The final result is a true collaboration of those who know what it takes to be productive and successful.

CAB FEATURES	CLASSIC	DIAMOND
Cab Trim Panels	Easy-to-Clean Plastic	Easy-to-Clean Plastic
Door Trim	Single Piece Door Panel with Integrated Door Pocket	Single Piece Door Panel with Integrated Door Pocket
Trim Inserts	Neutral	Mineral Teak
Instrument Panel	Black	Black
Gauge Cluster	Base Level: 3" Monochromatic Display Premium Level: 5" LCD Color Display	Base Level: 3" Monochromatic Display Premium Level: 5" LCD Color Display
Accent Color	Neutral	Dark Neutral
Sun Visors	Two	Three
Lighting	LED	LED
Window Controls	Manual or Power	Power
Lock Controls	Manual or Power	Power
Cup/Bottle Holders	Four	Four
Overhead Console	Molded Plastic with Retainer Nets and CB Radio Housing	Molded Plastic with Retainer Nets and CB Radio Housing
USB Accessory Port	Up to 5 Available	Up to 5 Available

UNDERFOOT AND AT YOUR FINGERTIPS.

PARTS AND SPECIFICATIONS

01	Steering Wheel	Adds more functions at the driver's fingertips with integrated programmable switch pods. The switches are backlit with laser-etched labels for improved durability and visibility. Plus, all the controls within the cab are designed to be operated easily while wearing gloves
02	Shifter	Featuring the T shifter. Optional Stalk shifter* is mounted on the steering column, allowing the you to easily reach and smoothly operate shifting and engine braking, while keeping your eyes on the road and hands on the wheel.
03	Instrument Panel	Includes a center-mounted vent to keep the middle passenger comfortable while providing space for extra legroom, optional storage components or a large floor-mounted body control module
04	Factory-Installed Switches	A single countershaft with helical gears lowers the overall weight of the unit without compromising the durability or performance of the transmission

*Available on the Allison 1000 & 2000 and required on the Allison 3000

Uptime is much more than simply being able to work, it also requires giving drivers the tools they need to be seriously productive. It's why the International MV Series instrument cluster is tested, refined and then tested again to ensure optimal readability, usability and positioning. It's also why color, illumination, legibility and even gauge size is designed to deliver optimal viewing in varying light conditions, maximizing alertness and minimizing eye fatigue.

ADVANTAGES YOU CAN SEE CLEARLY.

The optional premium cluster includes a customizable digital display that provides a wealth of information for the driver, including:

Real-time fuel economy

Axle load*

Custom gauge settings*

Safety indicators*

Digital speedometer

Tire pressure*

*When added with optional feature code for required sensors.



MORE UPTIME. FROM THE TRUCK THAT HAS YOUR BACK.

Uptime. With the International MV Series, you get more of it. On the road and on the jobsite. Our trucks are built to carry the weight of your job, your reputation and your commitment to deliver – on time, every time. Uptime-friendly features include: aligned and extended maintenance schedules that reduce service visits; onboard diagnostics that self-monitor vehicle systems; reduced manufacturing complexity for easier servicing; aero breakaway mirrors that reduce chances of cab damage – and more.

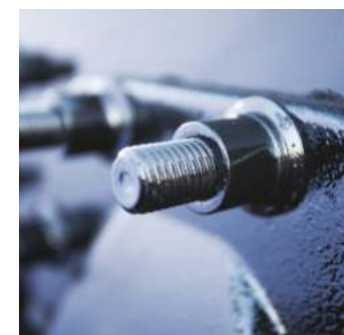

Huck® Bolt chassis fasteners provide consistently superior clamping force without re-torquing and won't come loose even in extreme environments.



Routine service points are clearly labeled and easily accessed under the hood.

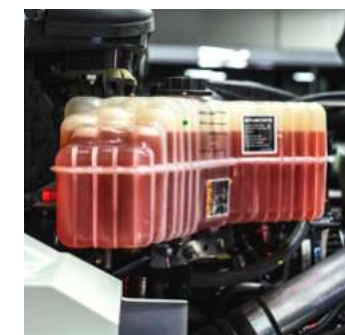

Key fluid reservoirs are translucent for quick inspection and many of the caps are tethered, saving time and frustration from dropped or lost caps.



In-cab electrical panel is protected from the elements and conveniently located under spill-resistant dash panel.



The International MV Series offers transmission choices (automatic, manual) that pair perfectly with your application needs, whether you're renting trucks to inexperienced customers or seeking optimal cost efficiency and productivity from veteran drivers.

TOUGH CHOICES. AUTOMATIC ADVANTAGES.



Allison Automatic with Optional FuelSense® 2.0
The Allison FuelSense® 2.0 with DynActive™ Shifting features a patented torque converter that provides infinitely variable shift points based on the vehicle configuration and operating conditions. FuelSense 2.0 can improve fuel economy up to 6% compared to previous generation FuelSense packages.



CUMMINS® B6.7

Every aspect of the Cummins® B6.7 has been engineered for reliability, durability and fuel efficiency to deliver the lowest cost of ownership with maximum uptime. Add industry-leading service from International® and Cummins, plus a three-year, unlimited mileage engine warranty, and it's easy to see why the B6.7 is the best-selling engine in the medium-duty truck market.

Specifications	Cummins B6.7
Engine Type	Diesel, 4-Cycle
Configuration	Inline 6-Cylinder
Displacement	409 cu. in. (6.7L)
Horsepower	200-360*
Bore and Stroke	4.21 x 4.88 in.
Aspiration	Variable Geometry Charger
Combustion System	High Pressure Common Rail (HPCR)
Engine Lubrication	15Q and 19Q
Total Engine Weight (Dry)	1,150 lbs.

HP Rating	Torque [lb-ft] @ RPM	Governed Speed [RPM]
200	600 @ 1600	2600
220	600 @ 1600	2600
240	600 @ 1600	2600
250	660 @ 1600	2600
260	660 @ 1600	2600
280	660 @ 1600	2600
300	660 @ 1600	2600
325	750 @ 1600	2600
340*	700 @ 1600	2600
360*	800 @ 1600	2600



CUMMINS® L9

The Cummins® L9 has established a solid reputation as a dependable engine for medium-duty applications. Its XPI Fuel System features multiple injection events per cycle for smoother, quieter operation. This, combined with its proprietary Variable Geometry Turbocharger (VGT), means the L9 has the highest power density of any engine in its class. In addition, replaceable wet sleeves help make the L9 easier and less expensive to rebuild, plus heavy-duty roller followers, bypass oil filtration and targeted piston cooling all contribute to longer service life.

Specifications	Cummins L9
Engine Type	Diesel, 4-Cycle
Configuration	Inline 6-Cylinder
Displacement	543 cu. in. (8.9L)
Horsepower	200-360**
Bore and Stroke	4.49 x 5.69 in.
Aspiration	Variable Geometry Charger
Combustion System	XPI Direct Injection
Engine Lubrication	20Q and 23Q
Total Engine Weight (Dry)	1,695 lbs.

HP Rating	Torque [lb-ft] @ RPM	Governed Speed [RPM]
260**	860 @ 1200	2200
270	860 @ 1200	2200
300	860 @ 1200	2200
330	1000 @ 1200	2200
350	1050 @ 1200	2200
360	1150 @ 1200	2200

* Rated for emergency vehicles only

** Not available for emergency applications

ITS GREATEST STRENGTH: SAFETY.



The International MV Series is built with safety as a top priority. It's the result of extensive studies into how drivers can stay safe and productive in a broad range of situations on the road or around a jobsite.

Safety often comes down to seeing potential hazards and successfully avoiding them. That's why the MV Series was designed with a sloped hood and optional LED headlights for enhanced visibility. An industry-leading HVAC system with MAX defrost can clear 100% of the windshield in under 30 minutes at 0° F. Plus, a traction control system can help drivers maintain control during heavy braking and on slick roads.

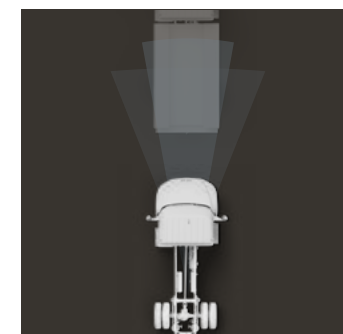

OPTIONAL BENDIX® WINGMAN® ADVANCED

- Uses radar to scan the forward path of the truck
- Distance alerts and, if necessary, active braking to help the driver potentially avoid the collision or help reduce its severity
- Adaptive cruise control with braking
- Collision mitigation technology and full-stability technology
- Includes Bendix® ESP® full-stability system

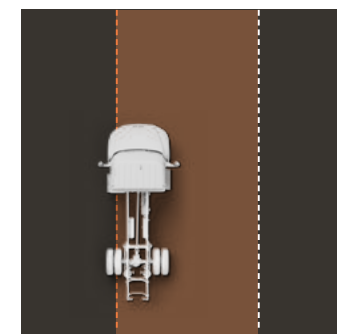

OPTIONAL BENDIX® WINGMAN® FUSION

The Bendix® Wingman® Advanced™ and Bendix® Wingman collision mitigation systems can greatly enhance operator safety. By integrating adaptive cruise control, lane departure warning, over-speed alert and stationary vehicle braking, these cutting-edge systems can help the driver potentially avoid a collision or help reduce its severity.

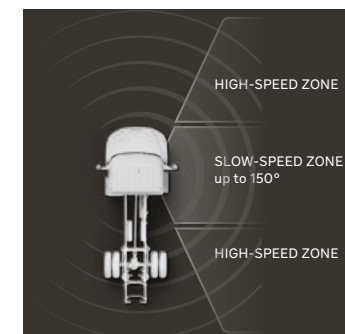

OPTIONAL BENDIX® BLINDSPOTTER®

When connected to the vehicle's Control Area Network (CAN), the optional Bendix BlindSpotter® provides a 150° range of coverage capable of detecting objects up to 20 feet in front of and 20 feet behind the BlindSpotter radar. The coverage zone extends up to 10 feet to the right of the vehicle. BlindSpotter minimizes false alerts by operating in two modes: highway speeds and lower speeds.



OPTIONAL HEATED LED HEADLIGHTS

LED headlights offer unparalleled nighttime visibility for improved safety, whether you're inside the cab or out.



MV SERIES VERSATILITY.

CAB SIZE OPTIONS



Regular Cab



Extended Cab



Crew Cab

AVAILABLE INTEGRAL FRAME EXTENSIONS



BODY APPLICATIONS

The International MV Series is ready to accept nearly any body — from a contractor's dump to a flatbed — usually without any special modifications or reinforcements.



TEM-READY. CUSTOMER FOCUSED.

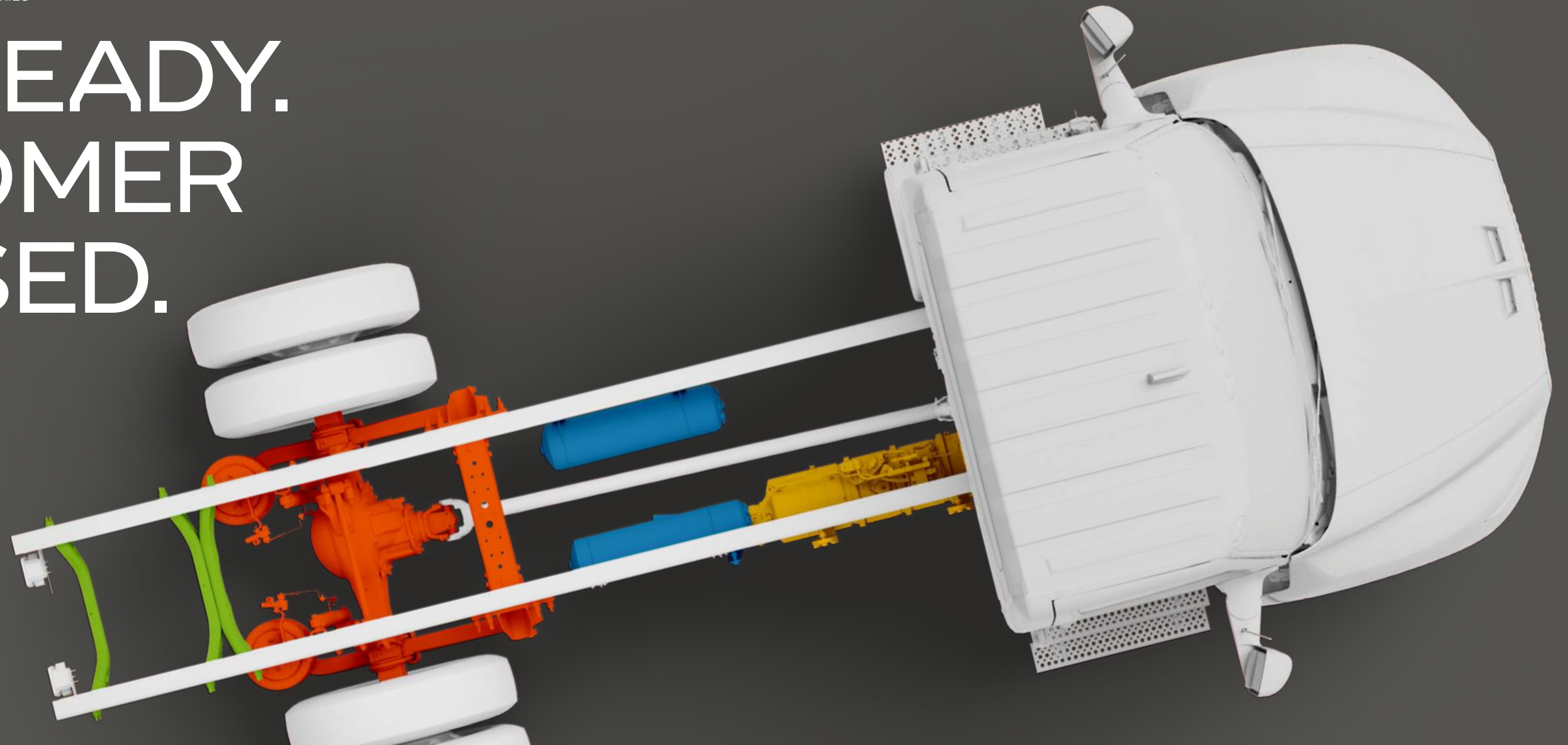

The more specialized your needs, the more our teams at International can deliver. We combine TEM-friendly body installation with unmatched application expertise to provide virtually unlimited upfit capabilities. Our engineers will work directly with your dealer, allowing you to order the specific foundation needed for your application up front, substantially reducing the time and expense of upfitting your truck post-production.

Every International MV Series truck starts with a Huck-bolted frame and crossmember system to deliver maximum vocational durability and multiple frame rail options. Air tanks, fuel tanks, battery boxes and exhaust systems can all be mounted in various positions to better align with your application. Recent driver-focused features improve visibility and maneuverability. Maintenance has also been simplified with a partial open hood (instead of hatches) and an underhood work light.

Our MV Series trucks are also available with a clean cab-to-axle (CA) configuration to help minimize costly post-production modifications.

BODY COMPANY BENEFITS

- Optimized chassis package
- Custom frame piercing to minimize open holes and maximize frame strength
- Huck-bolted frame ladder for durability and dependability
- Customized component locations to meet body packaging requirements
- Available integral front frame extensions
- Single 7/16", 2.4 million RBM straight frame rail provides high strength without added weight or risk of corrosion
- A clean cab-to-axle configuration (Clean CA)

POPULAR APPLICATIONS INCLUDE:

- Dump
- Crane
- Recovery
- Utility
- Bucket Truck
- Digger Derrick
- Van Body
- Stake
- Snowplow
- Flatbed

DIAMOND PARTNER

Delivering more uptime by bringing TEMs and dealers closer together

The Diamond Partner Program creates a conduit between International, our dealers and TEMs by providing industry-leading body-builder support materials and services. This program makes it easy for TEMs to mount their equipment faster, with a higher build quality and lower costs. In addition, this program facilitates joint marketing opportunities that can help increase awareness of dealer/TEM partnerships.

To learn more and/or sign up, please visit international.com/products/resources/tem-body-builder

International Truck Specialty Centers

A resource within International® that can provide quick, efficient and cost-effective upfitting solutions. You can count on:

- Quality modifications covered under manufacturer's warranty
- Upfit process supervised by International engineers to ensure factory production-level quality
- Expertise to identify and resolve problems quickly
- A quick and efficient process ensured by optimized delivery cycle times and comprehensive factory support

WHEN PUSH COMES TO PLOW.



With a stout, Huck-bolted frame and proven Cummins® power, an International MV Series truck makes an ideal snow-pushing beast. A 20-inch integrated front frame extension accommodates the blade. There's a plow and light connection and all road speed and other wiring is integrated into the vehicle (not into the dash). A heated windshield and sealed battery terminals are options you can choose to add to the package. There's also an optional transmission power take-off (PTO) to help power the plow. You can even choose between two fixed grilles – all black or black with chrome surround.

APPLICATION-SPECIFIC OPTIONAL FEATURES

- Front frame extension – 20" integral (no mega-brackets)
- Plow light connection
- Road speed and other wiring located either in the dash or behind the seat, depending on specific application needs
- Heated windshield
- Front axle 14.7K (Dana Spicer E-1462I)
- Front suspension (parabolic taper leaf, shackle type)
- Transmission PTO is available
- Sealed battery terminals

Frame Extension Configuration	Plow Width	Plow Mass	Hitch	Total
Optional Integral	11'	2,000 lbs.	500 lbs.	2,500 lbs.
Optional Bolt-On	10'	1,250 lbs.	100 lbs.	1,350 lbs.



INTERNATIONAL® DIAMOND LOGIC® ELECTRICAL SYSTEM. ADVANCING THE SCIENCE OF PRODUCTIVITY.

The International MV Series includes the International® Diamond Logic® electrical system, widely considered the most advanced in the industry. Diamond Logic streamlines chassis and body equipment integration and allows you to program automated tasks. This means more consistent performance and increased crew safety and equipment protection. It's easy to spec, simplifies integration and includes on-board diagnostics that self-monitor vehicle components to reduce downtime.

You even have the ability to write custom logic for your application through Diamond Logic® Builder.

01	Body Controller	Heart of the International Diamond Logic System. Performs all body integration software execution to maximize safety, performance and ease of equipment installation
02	Switch Packs	<ul style="list-style-type: none"> All switches are controlled via six wires Blinking switch indicators provide equipment status Switches can be moved without moving wiring Up to seven colors of lights can be used
03	Pre-Trip Light Inspections	Driver can press a button and all the exterior lights will blink in sequence, allowing daily DOT light inspection with just one person
04	PTO Power Take Off	<ul style="list-style-type: none"> Engagement and disengagement based on chassis and body conditions (engine speed, road speed, outrigger deployed before boom can raise, park brake set, transmission in neutral, etc.) Certain data links can be used as an interlock including RPM, MPH, Park Brake and gear position Engine speed can be controlled (in most cases) while using the PTO with no additional wiring needed
05	Remote Power Modules	All 12-volt outputs are automatically fused (auto-resettable) with solid state technology
06	Outriggers	Diamond Logic can sense when they are not properly stowed and will illuminate an indicator light in the switch packs while sounding an audible alarm
07	Differential Lock	Diamond Logic can control when the axle differential locks and unlocks depending on road speed, protecting the driveline from damage due to excessive speeds in a locked position
08	Work Light	<ul style="list-style-type: none"> Diamond Logic can automatically turn on or turn off the light based on chassis functions (for example: rear-facing light could be programmed to turn on any time the transmission is in reverse adding additional lighting) Automatically shut off the work light based on a set forward speed
09	Boom Hydraulics	Diamond Logic can sense when they are not properly stowed and will illuminate an indicator light in the switch packs with an audible alarm
10	Solenoid Air Packs	Air can be turned on with a switch in the dash or controlled based on chassis and/or body functions (for example: tailgate air lock in dump applications can be programmed to not unlock unless the truck is driving below a certain speed)



CUSTOMIZING INTERNATIONAL DIAMOND LOGIC FOR YOUR UNIQUE TASKS.



Programmable Key Fob
The International MV Series features a programmable key fob that allows two Diamond Logic tasks (such as pre-trip light inspection) to be activated with the push of a button.



Programmable Switch Pods
To help drivers keep their eyes on the road and hands on the wheel, the steering wheel switch pods can be programmed via Diamond Logic to operate many body controls. This is especially useful for functions that are performed while the truck is moving.

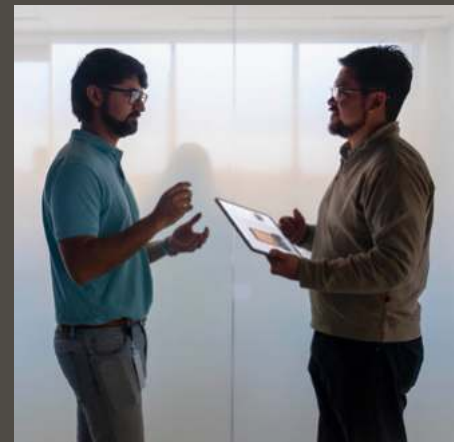

Diamond Logic Builder
MV Series customers have the ability to write custom logic so Diamond Logic can be easily expanded, configured and updated in the field to meet specific application requirements.

WE HAVE YOUR INDUSTRY-SPECIFIC SAFETY AND PRECISION RIGHT HERE.

Whether you're a municipality in search of an efficient, cost-effective solution, a Truck Equipment Manufacturer (TEM) in need of a rock-solid foundation for your next build, or a construction company wanting the toughest truck in the business, we have you covered. MV™ Series trucks armed with Diamond Logic will enable your crew to work with a level of security and accuracy that no other truck can offer.

SNOWPLOW



Body Lighting

Wiring is located in the back of the cab at the frame and includes sealed connectors for Tail/Amber Turn/Marker/Backup/Accessory Power/Ground and Sealed Connector for Stop/Turn

Power Take Off Control

Electric control with dash-mounted switch, includes audible alarm and indicator light in gauge cluster - provides safe control of the power take off with multiple interlocks

Road Speed Control

- Actual road speed can be used in logic to shut off PTO when truck goes over a predetermined/programmed road speed
- Road speed signal used as an input to body controllers (i.e. salt spreaders)
- Secondary road speed limit can trigger functionality through DLB to limit the truck speed. For example, the dump bed up signal from the body can be used to limit road speed

UTILITY



Body Lighting

Wiring is located in the back of the cab at the frame and includes sealed connectors for Tail/Amber Turn/Marker/Backup/Accessory Power/Ground and Sealed Connector for Stop/Turn

Remote Engine Speed Control

Remote-mounted body builder interface wiring for engine speed control with Cummins® ISB engines

Power Take Off Control

Electric control with dash-mounted switch, includes audible alarm and indicator light in gauge cluster - provides safe control of the power take off with multiple interlocks

RECOVERY

Wig-Wag Headlights

High-Beam with park brake interlock. Park brake disables high-beam wig wag, enables low-beam wig wag

High Amperage Switch

Control one auxiliary load up to 40 amps with a factory-installed switch for a high amperage load such as a light bar. Power available in "IGNITION" or "ACCESSORY" key states

Road Engine Speed Control

Remote-mounted body builder interface wiring for engine speed control with Cummins® ISB engines

Power Take Off Control

Electric control with dash-mounted switch, includes audible alarm and indicator light in gauge cluster - provides safe control of the power take off with multiple interlocks



LISLE, ILLINOIS
USA
International
FROM THE FIELD
TO THE FAST LANE
EST. 1902

OWNERSHIP SUPPORT.

- Connected Vehicle Services
- Service Communications
- International™ Financial

International is the first and only OEM to create connected solutions built for how you do business - designed on an open architecture, integrated with over 30 third party telematics providers, and compatible with all makes and models.*

INDUSTRY-LEADING CONNECTIVITY.

Take your performance to the next level. Our connected vehicle technology includes tools designed to give your business and operations that extra edge.

5 Years On Us

Factory installed telematics and five years of connected vehicle services are standard on new MV Series trucks.

OTA Programming

Ensure peak performance with remote software calibration and programmable parameter updates to the International® S13 Integrated Powertrain — anytime, anywhere.

Fleet Health Monitoring

Weekly reports on vehicles showing fault codes that are most likely to suggest a risk of roadside failure.

Gateway Integrations

Our factory installed telematics system can connect you to select fleet management and compliance software providers seamlessly, without the cost and complexity of additional hardware installation on your vehicle.

* For most commercial vehicles powered by diesel engines, 2007 MY and later.

Our Advanced Remote Diagnostics platform features:

- Reports on vehicle health issues that include severity ratings, likely needed parts and service, and recommended actions.
- Comprehensive vehicle health reports that include performance data, fault history and more.
- Up-to-date GPS location with customizable geofencing reports that can help ensure vehicles are where they need to be.
- Insights delivered how you need it — via our online portal, your email inbox, a mobile app and more.

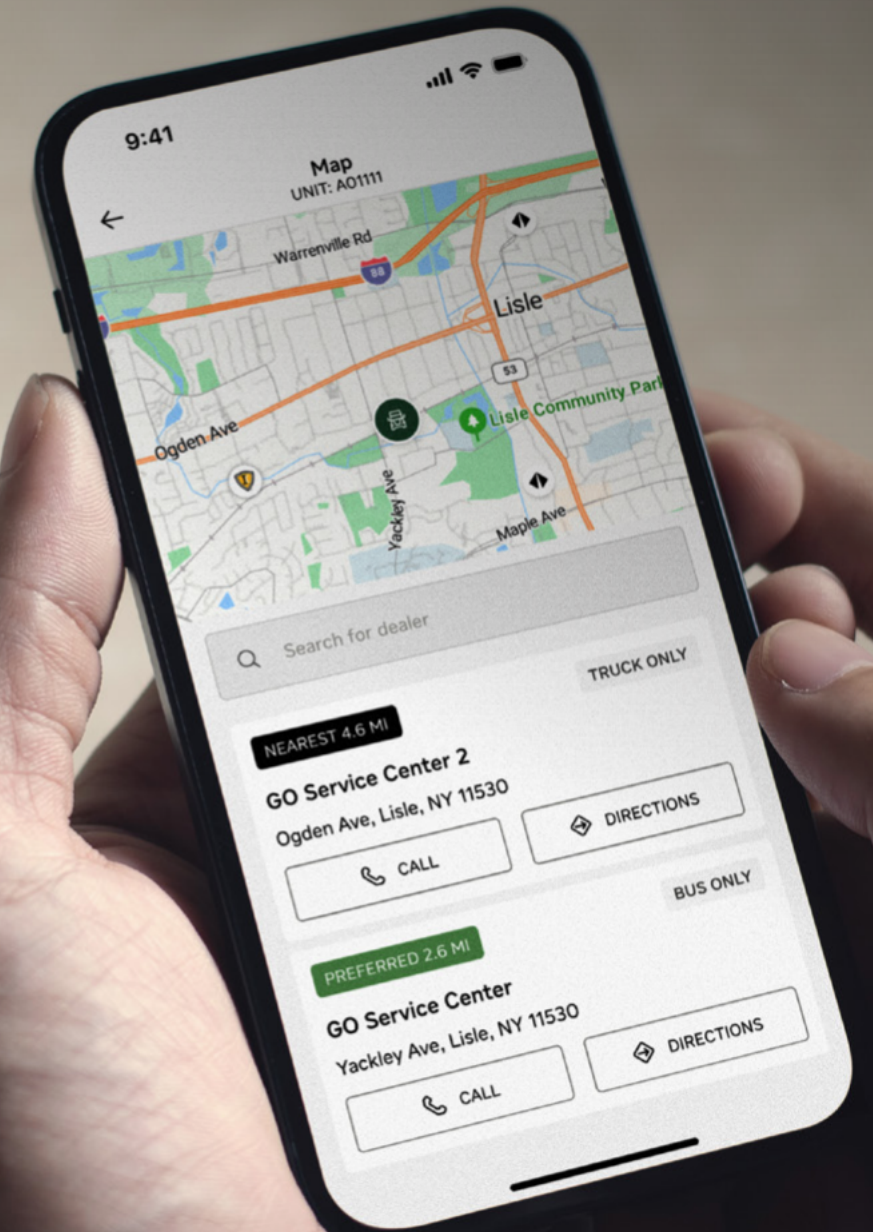

SERVICE COMMUNICATIONS WITH YOUR DEALER.

Our industry-leading service communications tool is designed to accelerate the repair process, streamline communications with your dealer service center and drive greater uptime.

FEATURES INCLUDE:

- Seamless communications with dealers, including service request initiation, up-to-date repair status, and estimate approvals
- Complete VIN-based information: asset specs, complete parts catalog, remote health data, and more
- Complete service history, up-to-date campaign information, and engine calibration status. Integration with parts inventory systems shows which dealer locations have the parts you need on the shelf now

5 YEARS ON US

- Service Communications is included for five years standard on new MV Series trucks.

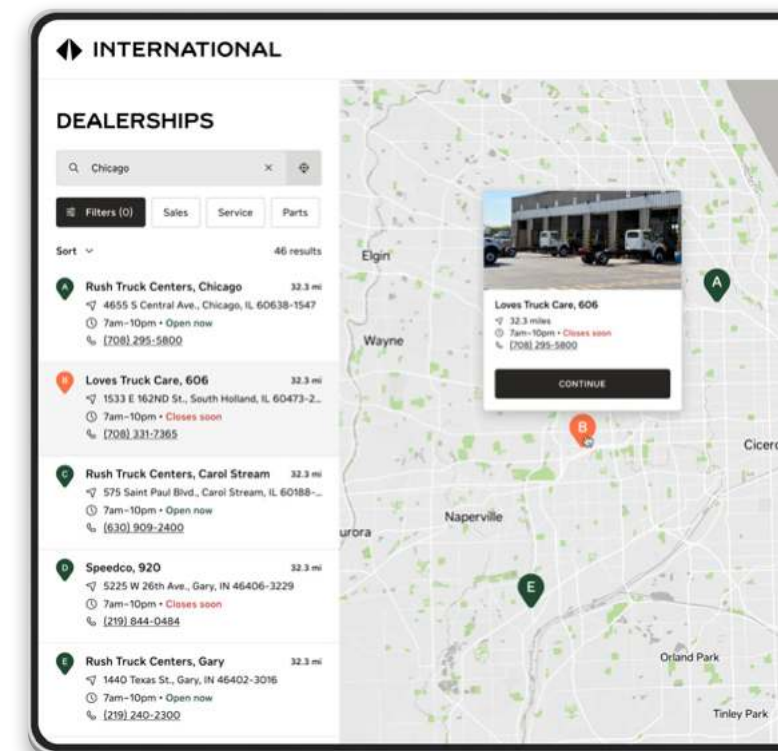

UNLOCK YOUR POTENTIAL.

International® Financial can help you take your business to the next level. We offer financing solutions for new and used International® trucks and IC Bus® school buses, as well as used vehicles of all makes and models offered through International® Truck dealers, IC Bus dealers and International® Used Truck Centers.

As an expert in the commercial vehicle industry, we have a deep understanding of your wants and needs and are ready to help enable your success.

We offer flexible solutions to fit your truck, bus, vehicle or equipment financing needs, helping you secure the best financing products for your specific situation. Whether you're looking for a fleet vehicle loan or you need to lease fleet vehicles, our financial team can provide you with the best option suited to your business.

THE CHOICE IS YOURS.

Fleet vehicle financing products have unique advantages and understanding those advantages can ensure your business selects the best financial solutions. The below comparison chart highlights the features and differences of our vehicle financing solutions.

Loan vs. Lease Comparison ^{1,2}	Loan	Finance Lease	TRAC Lease ³	Split TRAC Lease	FMV Lease
Flexible payment solutions	✓				
No mileage restrictions	✓	✓	✓		
Own equipment at end of term	✓	✓	✓	Optional	Optional
Finance lease for accounting purposes ²		✓	✓		
Lower payments			✓	✓	✓
Minimal initial cash outlay				✓	✓
No purchase obligation at lease termination				✓*	✓
Operating lease for accounting purposes ²				✓	✓

1. International™ Financial services and financing are provided by Navistar Financial Corporation. Program eligibility, actual payments, terms and down payment are determined by Navistar Financial Corporation's credit team based upon creditworthiness of customer.

2. Navistar Financial Corporation does not provide or endorse any tax or accounting advice or tax strategy to its dealers, customers or potential customers. You should consult with your own tax and accounting advisor on all such matters relating to the loan or lease financings described in this brochure.

3. TRAC leases are limited to motor vehicles leased to businesses and must be used for commercial purposes at least 50% of the time.

* Lessor & Lessee take pro-rata portion of the estimated residual value risk.



Making money means keeping your vehicles on the road.

That's why uptime is so important to us. Dependable equipment spec'd for your needs or requirements is just the beginning. We also focus on fuel economy, preventive maintenance, optimized service intervals and more to make sure the low cost of ownership of our vehicles helps keep you in the black.

Maximum Uptime Repair Before Failure

Prognostics move unplanned repairs to planned, optimizing maintenance using vehicle performance and predictive data.

Predictive Parts Stocking

Dealer parts inventory management uses AI and telematics data to predict stocking needs. This ensures the best parts are on dealer shelves to support customers.

Parts You Need Where and When You Need Them

Our partnership with Love's Truck Care & Speedco adds 400+ additional locations for quick, conveniently located access to light mechanical and select warranty work.*

International Dealer Locations

700

Love's Truck Care & Speedco Locations

400

Total Service Locations

1,100



TRUCK CARE

MV SERIES SPECIFICATIONS



MV Specifications

GVW	21,500 – 54,700 lbs.
Models/BBC/BA	MV607: 107.5" BBC, 40.4" BA MV60H: 107.5" BBC, 40.4" BA (Low Profile)
Cab Configurations	Regular Cab Extended Cab Crew Cab
Wheelbase Options	128" – 311"
Axle Configurations	4x2, 6x4
Rear Axle	Single Rear Axle (4x2) <ul style="list-style-type: none"> Meritor: 13,500 – 30,000 lbs. Dana Spicer: 13,500 – 30,000 lbs. Tandem Rear Axle (6x4) <ul style="list-style-type: none"> Meritor: 34,000 – 40,000 lbs. Dana Spicer: 40,000 lbs.
Front Axle	<ul style="list-style-type: none"> Meritor: 8,000 – 14,600 lbs. (4x2, 6x4) Dana Spicer: 8,000 – 14,700 lbs. Hendrickson Steertek: 10,000 – 12,000 lbs.
Frames	<ul style="list-style-type: none"> High-Strength Low-Alloy Steel 50,000 – 80,000 PSI Heat Treated Alloy Steel 120,000 PSI Clean CA available for body mounting
Front Suspension	Spring, Parabolic Taper Leaf: 8,000 – 14,700 lbs.
Rear Suspension	<ul style="list-style-type: none"> Spring, Single Vari-Rate: 13,500 – 31,000 lbs. Tandem, 4-Spring Multileaf: 34,000 – 40,000 lbs. IROS Air Suspension available for Single and Tandem Axle
Electrical System	Diamond Logic® Electrical System Alternators <ul style="list-style-type: none"> 12 Volt 160 – 325 Amp. Battery Systems <ul style="list-style-type: none"> 12 Volt, 2 to 3 Batteries Headlights <ul style="list-style-type: none"> Long Life Halogen, Optional LED
Exhaust System	Single, Horizontal, Aftertreatment Device Frame Mounted Right, Under Cab or Back of Cab, Horizontal or Vertical Tailpipe
Brakes	Hydraulic Disc with Four Channel ABS, Optional Traction Control Air Brakes with ABS, Optional Traction Control, Optional Electronic Stability Program with Traction Control
Steering	TRW/Ross Power Sheppard Power
Engines	<ul style="list-style-type: none"> Cummins B6.7: 200 – 360 hp and 520 – 750 lb.-ft. of torque* Cummins L9: 260 – 360 hp and 860 – 1,150 lb.-ft. of torque**
Transmissions	<ul style="list-style-type: none"> Eaton® Fuller: 6, 10 Speed Manual Allison: 1000, 2000, 3000 Series (HS, EVS, RDS, MH) Automatic Eaton® Fuller: Advantage 10 Speed Fully Automated Manual
Fuel Tank	40 – 140 Gallon Non-Polished and Polished Aluminum, Mounted Right Side, Left Side or Dual Under Cab
DEF Tank	5 – 16.5 Gallon
Tires	Continental, Michelin, Goodyear, Bridgestone, Hankook, Yokohama

*340 hp and 700 lb.-ft. of torque / 360 hp and 800 lb.-ft. torque ratings available for emergency vehicles only

**260 hp and 860 lb.-ft torque rating is not available for emergency

Find out more at
international.com

2701 Navistar Dr.
Lisle, IL, USA 60532



Note: The information and conclusions contained herein are believed to be correct at time of publication, but do not necessarily apply to similar vehicles with different specifications or with production dates after the production of this publication. Vehicles with different specifications or later dates of production may yield different results. Vehicle specifications are subject to change without notice. TAD21002 09/2024 ©2024 International Motors, LLC. All rights reserved. All marks are trademarks of their respective owners.

